



Request for Quotations For Goods

Supply & delivery of steel pipe specials, base frames, flexible pipe couplings, fasteners & gaskets for various projects

Procurement Reference No: G/RFQ/NW-006/2027

| | | | |
|---------------------------------|--------------|----------------|------------|
| Name of Bidder | | | |
| Contact Person | | | |
| E-mail Address | | | |
| Postal Address | | | |
| Total Amount (Excl. VAT) | | | |
| Lot 1: | N\$ | Lot 2: | N\$ |
| Lot 3: | N\$ | Lot 4: | N\$ |
| Lot 5: | N\$ | Lot 6: | N\$ |
| Lot 7: | N\$ | Lot 8: | N\$ |
| Lot 9: | N\$ | Lot 10: | N\$ |
| Lot 11: | N\$ | - | - |
| Contact Phone number | Work: | Mobile: | |

Documents must be posted / delivered to:

The Quotation/Bid Box

Att: Procurement Management Unit (+264 61 71 2015), bids@namwater.com.na

Namibia Water Corporation Ltd.
Private Bag 13389
176 Iscor Street, Aigams Building
Windhoek

**Closing Date: Thursday, 23 April 2026 at 11h00
NO LATE BIDS WILL BE ACCEPTED!**

NOTICE TO BIDDERS

- Please take note of initializing all pages of the standard bidding document and initial all the supporting documents including company profiles, brochures, etc.**
- Take note to sign all relevant pages as stipulated in the bidding standard document.**
- Copies of documents not certified by a Commissioner of Oath appointed in terms of the Justices of the Peace and Commissioners of Oaths Act.1963 (Act No. 16 of 1963) will not be accepted.**

Namibia Water Corporation Ltd.
Private Bag 13389, Windhoek, Namibia
Tel: +264 61 71 2081
Fax: +264 61 21 0741



Letter of Invitation

Name and Address of Bidder _____

Procurement Reference Number: G/RFQ/NW-006/2027

09 April 2026

Dear Bidder,

Supply & delivery of steel pipe specials, base frames, flexible pipe couplings, fasteners & gaskets for various projects

NamWater invites you to submit your best quote for the items described in detail hereunder.

Any resulting contract shall be subject, to the terms and conditions referred to in the document.

Queries, if any, should be addressed to Procurement Management Unit E-mail:

bids@namwater.com.na, Private Bag 13389 Windhoek, Namibia.

Please prepare and submit your quotation in accordance with the instructions given or inform the undersigned if you will not be submitting a quotation.

Yours faithfully

Procurement Management Unit

SECTION I: INSTRUCTIONS TO BIDDERS

1. Rights of Public Entity

The NamWater Ltd reserves the right:

- (a) to split the contract as per the lowest evaluated cost per item, or
- (b) to accept or reject any quotation; and
- (c) to cancel the quotation process and reject all quotations at any time prior to contract award.

2. Preparation of Quotations

You are requested to quote for the items mentioned in Section III by completing, signing and returning:

- (a) the Quotation Letter in Section II with its annex for Bid Securing Declaration;
- (b) the List of Goods and Price Schedule Section III;
- (c) the Specifications and Compliance Sheet in Section V; and
- (d) Supporting information/literature requested under Section IV, number 8

You are advised to carefully read the complete Request for Sealed Quotations document, including the Special Conditions of Contract in Section VII, before preparing your quotation. The standard forms in this document may be retyped for completion but the Bidder is responsible for their accurate reproduction.

3. Validity of Quotations

The Quotation validity period shall be **90** days from the date of submission deadline.

4. Eligibility Criteria

To be eligible to participate in this Quotation exercise, you should:

- (a) Have a certified copy (certified by a Commissioner of Oath appointed in terms of the Justices of the Peace and Commissioners of Oaths Act.1963 (Act No. 16 of 1963)), of a valid company Registration Document;
- (b) Have an original or a certified copy (certified by a Commissioner of Oath appointed in terms of the Justices of the Peace and Commissioners of Oaths Act.1963 (Act No. 16 of 1963)), of a valid Good Standing Tax Certificate, as certified by the Commissioner of Oath;
- (c) A valid good Standing Social Security Certificate;
- (d) Have a valid certified copy (certified by a Commissioner of Oath appointed in terms of the Justices of the Peace and Commissioners of Oaths Act.1963 (Act No. 16 of 1963)), of Affirmative Action Compliance Certificate, proof from Employment Equity Commissioner that bidder is not a relevant employer, or exemption issued in terms of Section 42 of the Affirmative Action Act, 1998 or a valid certified copy of the original document, as certified by the Commissioner of Oath;

- (e) Submit signed Bid-securing Declaration.
- (f) An undertaking on the part of the Bidder that the salaries and wages payable to its personnel in respect of this proposal are compliant to the relevant laws, Remuneration Order, and Award, where applicable and that it will abide to sub-clause 4.6 of the General conditions of Contract if it is awarded the contract or part thereof; and;
- (g) Submit a minimum of one (1) reference letter from reputable entities whom the Bidder has supplied goods of similar nature in the last three (3) years, and handled successfully.
- (h) Supporting information / literature for all the items offered to substantiate compliance, where applicable. These documents must be from the manufacturer or an authorised manufacturer's representative. Representatives must provide an authorised letter from the manufacturer confirming their status.
- (i) Bids from service providers appearing on the ineligibility lists of African Development Bank, Asian Development Bank, European Bank for Reconstruction and Development, Inter-American Development Bank Group and World Bank Group shall be rejected.

Links for checking the ineligibility lists are available at:

- Republic of Namibia, Procurement Policy Unit
<https://egp2.gov.na/forms/SearchSuspendedBidders.jsf>
- African Development Bank
<https://www.afdb.org/en/projects-operations/debarment-and-sanctions-procedures>
- Asian Development Bank
<http://lnadbg4.adb.org/oga0009p.nsf/sancALLPublic?OpenView&count=999>
- European Bank for Reconstruction and Development
<http://www.ebrd.com/pages/about/integrity/list.shtml>
- Inter-American Development Bank Group
<http://www.iadb.org/en/topics/transparency/integrity-at-the-idb-group/sanctioned-firms-and-individuals,1293.html>
- World Bank Group
<http://www.worldbank.org/en/projects-operations/procurement/debarred-firms>

5. Bid Security/Bid Securing Declaration

Bidders are required to subscribe to a Bid Securing Declaration for this procurement process.

6. Delivery

The Goods are to be delivered within **8 weeks** from the date of Purchase Order or Letter of Acceptance.

Deviation in delivery period **shall not be accepted.**

7. Sealing and Marking of Quotations

Quotations should be sealed in a single envelope, clearly marked with the Procurement Reference Number, addressed to NamWater Ltd with the Bidder's name and contact information at the back of the envelope.

8. Submission of Quotations

Quotations should be deposited in the Quotation/Bid Box located at Namibia Water Corporation Ltd Head office, Private Bag 13389, 176 Iscor Street, Aigams Building, Windhoek, not later than **Thursday 23 April 2026 at 11h00**. Offers by post or hand delivered should reach Private Bag 13389 by the same date and time at latest. Late Offers will be rejected

Quotations received by e-mail will not be considered.

9. Opening of Quotations

Quotations will be opened internally by NamWater Ltd immediately after the closing time referred to in instruction 8 above. A record of the Quotation Opening stating the name of the bidders, the amount quoted, the presence or absence of a Bid Securing Declaration, will be posted on the website of NamWater Ltd and available to any bidder on request within three working days of the Opening.

10. Evaluation of Quotations

NamWater shall have the right to request for clarifications in writing during evaluation.

Substantially responsive offers will be evaluated according to the following formula to determine the percentage score:

11. Technical Compliance

Bidders shall submit along with their quotations documents, catalogues and any other literature to substantiate compliance with the required specifications and to qualify deviations if any with respect to Public Entity's requirements.

The Specifications, Performance Requirements and Compliance Sheet details the minimum specifications of the goods/items to be supplied. The specifications have to be met but no credit will be given for exceeding the specifications unless otherwise stated.

12. Prices and Currency of Payment

Prices shall be fixed in Namibian Dollars.

13. Margin of Preference

Not Applicable

14. Award of Contract

The Bidder having submitted the lowest evaluated responsive quotation and qualified to supply the goods/items and related services shall be selected for award of contract. Award of contract shall be by issue of a Purchase Order/Letter of Acceptance in accordance with terms

and conditions contained in Section VI: Contract Agreement and General Conditions of Contract.

15. Notification of Award and Debriefing

NamWater Ltd shall after award of contract promptly inform all unsuccessful bidders in writing of the name and address of the successful bidder and the contract amount and post a notice of award on its website within seven (7) days. Furthermore, NamWater Ltd shall end to all requests for debriefing made in writing within seven (7) days of the unsuccessful bidders being informed of the award.

SECTION II: QUOTATION LETTER

(to be completed by Bidders)

*[Complete this form with all the requested details and submit it as the first page of your quotation with the Price list and documents requested above. A signature and authorisation on this form will confirm that the terms and conditions of the RFQ prevail over any attachments. **If your quotation is not authorised, it will be rejected.**]*

| | |
|--------------------------------|---|
| Quotation addressed to: | Namibia Water Corporation Ltd |
| Procurement Reference Number: | G/RFQ/NW-006/2027 |
| Subject matter of Procurement: | Supply & delivery of steel pipe specials, base frames, flexible pipe couplings, fasteners & gaskets for various projects |

We offer to supply the items listed in the attached List of Goods and Price Schedule as per the defined specifications, *except for the qualified deviations [Bidder may delete this phrase in case of no deviation]* and, in accordance with the terms and conditions stated in your Request for Quotations referenced above.

We confirm that we are eligible to participate in this Quotation exercise and meet the eligibility criteria specified in Section 1: Instruction to Bidders.

We undertake to abide ethical conduct during the procurement process and the execution of any resulting contract.

We have read and understood the content of the Bid Securing Declaration (BSD) attached hereto and subscribe fully to the terms and conditions contained therein. We further understand that this subscription could lead to disqualification on the grounds mentioned in the BD].

The validity period of the Quotation is days from the date of the bid submission deadline.

We confirm that the prices quoted in the List of Goods and Price Schedule are fixed and firm and will not be subject to revision or variation, if we are awarded the contract **prior to the expiry** date of the quotation validity.

The delivery period offered from the date of issue of Purchaser Order/ Letter of Acceptance is as shown in the List of Goods items and Price Schedule.

Quotation Authorised by:

| | | | |
|---|--|----------------------------|------------|
| Name of Bidder | | Company's Address and seal | |
| Contact Person | | | |
| Name of Person Authorising the Quotation: | | Position: | Signature: |
| Date | | Phone No./Fax | |

Appendix to Quotation Letter

**BID SECURING DECLARATION
(Section 45 of Act)
(Regulation 37(1)(b) and 37(5))**

Date:

Procurement Ref No.:

To:

I/We* understand that in terms of section 45 of the Act a public entity must include in the bidding document the requirement for a declaration as an alternative form of bid security.

I/We* accept that under section 45 of the Act, I/we* may be suspended or disqualified in the event of

- (a) a modification or withdrawal of a bid after the deadline for submission of bids during the period of validity;**
- (b) refusal by a bidder to accept a correction of an error appearing on the face of a bid;**
- (c) failure to sign a procurement contract in accordance with the terms and conditions set forth in the bidding document, should I/We* be successful bidder; or**
- (d) failure to provide security for the performance of the procurement contract if required to do so by the bidding document.**

I/We* understand this bid securing declaration ceases to be valid if I am/We are* not the successful Bidder

Signed:
[insert signature of person whose name and capacity are shown]

Capacity of:
[indicate legal capacity of person(s) signing the Bid Securing Declaration]

Name:
[insert complete name of person signing the Bid Securing Declaration]

Duly authorized to sign the bid for and on behalf of: [insert complete name of Bidder]

Dated on _____ day of _____, _____
[insert date of signing]

Corporate Seal (where appropriate)

[Note*: In case of a joint venture, the bid securing declaration must be in the name of all partners to the joint venture that submits the bid.]

**delete if not applicable / appropriate*



Republic of Namibia

Ministry of Labour, Industrial Relations and Employment Creation

Written undertaking in terms of section 138 of the Labour Act, 2015 and section 50(2)(D) of the Public Procurement Act, 2015

1. EMPLOYERS DETAILS

Company Trade Name:.....

Registration Number :.....

Vat Number:

Industry/Sector:

Place of Business:.....

Physical Address:.....

Tel No.:.....

Fax No.:.....

Email Address:.....

Postal Address:.....

Full name of Owner/Accounting Officer:.....

.....

Email Address:.....

2. PROCUREMENT DETAILS

Procurement Reference No.:.....

Procurement Description:

.....

.....

Anticipated Contract Duration:

Location where work will be done, good/services will be delivered:

.....

3. UNDERTAKING

I [insert full name], owner/representative

of[insert full name of company]

hereby undertake in writing that my company will at all relevant times comply fully with the relevant provisions of the Labour Act and the Terms and Conditions of Collective Agreements as applicable.

I am fully aware that failure to abide to such shall lead to the action as stipulated in section 138 of the labour Act, 2007, which include but not limited to the cancellation of the contract/licence/grant/permit or concession.

Signature:

Date:

Seal:.....

Please take note:

1. *A labour inspector may conduct unannounced inspections to assess the level of compliance*
2. *This undertaking must be displayed at the workplace where it will be readily accessible and visible by the employees rendering service(s) in relations to the goods and services being procured under this contract.*

| | | | | | | |
|-----|---|----|------|--|--|--|
| 9. | HDG 50NB Spool piece | 2 | Each | | | |
| 10. | HDG 50NB Flanged distance piece with restraining flange and 25mm socket (SANS 1123/1000/3) | 2 | Each | | | |
| 11. | HDG 50NB Flanged 90° bend (SANS 1123/1000/3) | 3 | Each | | | |
| 12. | HDG 50NB T-Piece with restraining flange welded onto middle of T | 1 | Each | | | |
| 13. | HDG 50NB Flanged T-piece with restraining flange (SANS 1123/1000/3) | 1 | Each | | | |
| 14. | HDG 50NB Flanged T-piece (SANS 1123/1000/3) | 1 | Each | | | |
| 15. | HDG 200NB Flanged manifold with one 200NB stub, three 80NB eccentric stubs and one 50NB stub (SANS 1123/1000/3) | 1 | Each | | | |
| 16. | HDG 150NB Flanged manifold with one 150NB stub, three concentric 80NB stubs and two 50NB stubs (SANS 1123/1000/3 and SANS 1123/1600/3) | 1 | Each | | | |
| 17. | HDG 80NB Distance piece with two restraining flanges (SANS 1123/1000/3) | 2 | Each | | | |
| 18. | HDG 80NB Flanged distance piece with restraining flange and 25mm socket (SANS 1123/1600/3) | 2 | Each | | | |
| 19. | HDG 80NB Flanged distance piece with restraining flange (SANS 1123/1600/3) | 2 | Each | | | |
| 20. | HDG 150NB Flanged T-piece with restraining flange (SANS 1123/1000/3) | 1 | Each | | | |
| 21. | HDG 200NB to 100NB Flanged concentric reducer (SANS 1123/1600/3) | 1 | Each | | | |
| 22. | HDG Pipe support base | 10 | Each | | | |
| 23. | HDG 200NB Pipe support (Complete with nut and washer) | 4 | Each | | | |
| 24. | HDG 150NB Pipe support (Complete with nut and washer) | 3 | Each | | | |
| 25. | HDG 50NB Pipe support (Complete with nut and washer) | 2 | Each | | | |
| 26. | Stainless steel 50NB spool piece with lap flange and threaded plain end | 5 | Each | | | |

| | | | | | | |
|-----------------|--|-----------|------|-----------|--------------|------|
| 27. | HDG 100NB Flanged distance piece | 1 | Each | | | |
| 28. | HDG 50NB Blank flange with 25mm socket (SANS 1123/1000/3) | 10 | Each | | | |
| 29. | HDG 200NB Blank flange (SANS 1123/1000/3) | 2 | Each | | | |
| 30. | HDG 150NB Blank flange (SANS 1123/1000/3) | 3 | Each | | | |
| 31. | HDG 150NB Blank flange with blind 25mm socket (SANS 1123/1000/3) | 1 | Each | | | |
| 32. | HDG 80NB Blank flange (SANS 1123/1600/3) | 1 | Each | | | |
| 33. | HDG 80NB Blank flange (SANS 1123/1000/3) | 1 | Each | | | |
| 34. | HDG 50NB Blank flange (SANS 1123/1000/3) | 4 | Each | | | |
| 35. | HDG 150NB Weld-on flange (SANS 1123/1000/3) | 2 | Each | | | |
| 36. | HDG Large pump base frame | 1 | Each | | | |
| 37. | HDG Medium pump base frame | 1 | Each | | | |
| 38. | HDG Small pump base frame | 1 | Each | | | |
| | Delivery [Weeks] | | | | TOTAL | |
| NAME: | | POSITION: | | SIGNATURE | | DATE |
| NAME OF BIDDER: | | ADDRESS: | | | | |

Currency: N\$ Exchange Rate: N/A

Key notes: **NA**=NOT APPLICABLE, **NQ**=NO QUOTE

| | | | |
|-----------------|-----------|-----------|------|
| NAME: | POSITION: | SIGNATURE | DATE |
| NAME OF BIDDER: | ADDRESS: | | |

Currency: N\$ Exchange Rate: N/A

Key notes: NA=NOT APPLICABLE, NQ=NO QUOTE

SECTION IV: SPECIFICATIONS AND PERFORMANCE REQUIREMENTS

Pipework

All flanges of fabricated pipe specials shall conform to SANS 1123/1000/3 or SANS 1123/1600/3 as denoted in the table in Section 3, Description of Goods. **1123/1600/3 Flanges are also denoted as such in the drawings.**

All flanges of pipe specials shall be fitted in the two-hole-top off the centreline configuration.

Steel pipes up to and including 150NB shall conform to SABS 62.

Steel pipes 200NB and larger shall conform to SABS 719 Grade B or SABS 719 Grade C.

Unless otherwise stated, all manufactured pipe specials shall comply with the following specifications:

| Nominal Diameter | Outside Diameter | Minimum Wall Thickness |
|------------------|------------------|------------------------|
| 25NB | 33.7mm | 3.3mm |
| 32NB | 42.4mm | |
| 50NB | 60.3mm | |
| 80NB | 88.9mm | 4.5mm |
| 100NB | 114.3mm | |
| 150NB | 168.3mm | |
| 200NB | 219.1mm | |
| 300NB | 323.9mm | |

All sockets will be steam sockets with a minimum wall thickness of 3mm.

All pipework welding shall be done in accordance with SANS 10044 for steel fusion welding. Mating surfaces shall be continuously welded all around their mating periphery.

All steel surfaces shall be blast clean to SABS 064 and the final finishing shall comply with S.I.S. 05 5900 grade Sa 2.5. before galvanizing.

Unless otherwise stated, all pipe specials, flanges and flexible pipe coupling items shall be hot dip galvanized to SABS ISO 1461:1999. The average galvanizing layer thickness shall furthermore not be less than 150 micron and the minimum thickness at any spot not less than 100 micron.

Pipework Couplings

Flexible flange adaptor couplings will be supplied and delivered to join plain-ended pipes to flanged valves, fittings and pipes to allow for angular misalignment and axial adjustment.

Only **Klamflex** flexible pipe couplings shall be acceptable. **The bidder shall submit supporting literature of the couplings offered.**

All flanges of flexible couplings shall conform to SANS 1123/1000/3 or SANS 1123/1600/3 as denoted in the table in Section 3, Description of Goods.

All coupling welding shall be done in accordance with SANS 10044 for steel fusion welding.

All flange adaptors shall be complete and ready for installation with the necessary sleeves, rubber wedge rings and clamping bolts and nuts.

All dedicated flange adaptors shall be suitable for installation with restraining rods. Should dedicated flange adapters have a raised edge that contacts the gasket with installation, not less than 90% of the appropriate gasket area shall be in contact with the flange adapter. Flush faced flange adapters will be preferred.

All steel surfaces shall be blast clean to SABS 064 and the final finishing shall comply with S.I.S. 05 5900 grade Sa 2.5. before galvanizing.

Unless otherwise stated, all pipe specials, flanges and flexible pipe coupling items shall be hot dip galvanized to SABS ISO 1461:1999. The average galvanizing layer thickness shall furthermore not be less than 150 micron and the minimum thickness at any spot not less than 100 micron.

Corrosion Protection of Pipework and Couplings

All steel surfaces shall be blast clean to SABS 064 and the final finishing shall comply with S.I.S. 05 5900 grade Sa 2.5. before galvanizing or primer.

Unless otherwise stated, all pipe specials, flanges and flexible pipe coupling items shall be hot dip galvanized to SABS ISO 1461:1999. The average galvanizing layer thickness shall furthermore not be less than 150 micron and the minimum thickness at any spot not less than 100 micron.

Fasteners

The bolts to be of **grade 4.8** unless stated otherwise. All fasteners where applicable shall be ISO metric according to SABS 135. All bolts, nuts, threaded rods and washers shall be hot dip galvanized as per SABS ISO 1461: 1999. Electroplated bolts, nuts and washers shall not be accepted.

The fasteners shall be packaged in suitable woven bags with appropriate labelling. The bags shall then be crated for transport and delivery. Each lot of fasteners and gaskets shall be crated separately.

Gaskets

The gasket OD should be dictated by the flange specifications. The gaskets shall be of non-asbestos compressed fiber or graphite type. The gaskets shall be suitable for potable and raw water at temperatures from 0°C to 60°C. The gaskets shall have a thickness of 3mm. **Full faced gaskets will not be accepted.**

Stainless Steel Pipework

Made of stainless-steel grade 304 or superior. 50NB barrels shall have a minimum wall thickness of 3.3mm. All welding shall be done in accordance with SANS 10044 for steel fusion welding.

Packaging

Each lot shall be packaged separately. The bidder is responsible for clearly marking the items and separating them into the lots. NamWater will not sort items upon delivery.

SECTION V: SPECIFICATIONS AND COMPLIANCE SHEETS

Procurement Reference Number: G/RFQ/NW-006/2027

| Lot No | Technical Specification Required | Technical Specification Offered | Offer Complies | |
|----------|---|---------------------------------|----------------|----------|
| | | | Yes | No |
| <i>A</i> | <i>B</i> | <i>C</i> | <i>D</i> | <i>E</i> |
| 1-4 | All flanges as denoted conform to SANS 1123/1000/3 or 1123/1600/3 as denoted | | | |
| | Steel pipes 200NB and larger shall comply with SABS 719 Grade B or SABS 719 Grade C | | | |
| | Steel pipes 150NB and smaller shall comply with SABS 62 | | | |
| | Pipe wall thickness as specified | | | |
| | Sockets are steam sockets | | | |
| | Welding in accordance with SANS 10044 for steel fusion welding | | | |
| | Mating surfaces continuously welded all around their mating periphery | | | |
| | Corrosion protection as specified | | | |

| Lot No | Technical Specification Required | Technical Specification Offered | Offer Complies | |
|----------|--|---------------------------------|----------------|----------|
| | | | Yes | No |
| <i>A</i> | <i>B</i> | <i>C</i> | <i>D</i> | <i>E</i> |
| 5-7 | All flanges as denoted conform to SANS 1123/1000/3 or 1123/1600/3 as denoted | | | |
| | Klamflex dedicated flange adapters suitable for mild steel pipe according to SABS 719/71 | | | |
| | Welding in accordance with SANS 10044 for steel fusion welding | | | |
| | Mating surfaces continuously welded all around their mating periphery | | | |
| | Corrosion protection as specified | | | |

| Lot No | Technical Specification Required | Technical Specification Offered | Offer Complies | |
|----------|---|---------------------------------|----------------|----------|
| | | | Yes | No |
| <i>A</i> | <i>B</i> | <i>C</i> | <i>D</i> | <i>E</i> |
| 8-11 | All fasteners where applicable shall be ISO metric according to SABS 135 | | | |
| | All fasteners hot dip galvanized as per SABS ISO 1461: 1999 | | | |
| | Gaskets suitable for potable and raw water at temperatures from 0°C to 60°C | | | |
| | Gasket 3mm thickness | | | |
| | Ring Klinger gasket (not full faced) | | | |

Bidders should complete column C with the specification offered. Attach detailed technical literature. Authorise the specification offered in the signature block below.

All Tenders shall be accompanied with **detailed supporting literature for all couplings** to enable NamWater to evaluate the conformity to specification.

Offers with insufficient details or information will not be considered.

NOTE:

Offers will be disqualified if this information is not included in the tender documents. Only original documentation is acceptable.

Specifications and Compliance Sheet Authorised By:

| | | | |
|----------------------------------|--|------------|--|
| Name: | | Signature: | |
| Position: | | Date: | |
| Authorised for and on behalf of: | | Company | |

SECTION VI: GENERAL CONDITIONS OF CONTRACT AND CONTRACT AGREEMENT

Any resulting contract shall be placed by means of a Purchase Order/Letter of Acceptance and shall be subject to the General Conditions of Contract (GCC) for the Procurement of Goods - Ref. G/RFQ-GCC on the website of NamWater Ltd (www.namwater.com.na) except where modified by the Special Conditions below.

SECTION VI: CONTRACT AGREEMENT

Any resulting contract shall be placed by means of a Purchase Order/Letter of Acceptance and shall be subject to the General Conditions of Contract (GCC) for the Procurement of Goods except where modified by the Special Conditions below.

SECTION VIII: SPECIAL CONDITIONS OF CONTRACT

Procurement Reference Number : G/RFQ/NW-006/2027

The clause numbers given in the first column correspond to the relevant clause number of the GCC.

| Subject and GCC clause reference | Special Conditions |
|--|---|
| Purchaser GCC 1.1(h) | The purchaser is: NamWater |
| Site GCC 1.1(m) | The Site/final destination for delivery of the Goods is 176 Iscor Street NamWater at the Aigams Building, Northern Industrial Area in Windhoek |
| Incoterms Edition GCC 4.2(b) | Incoterms shall be governed by the rules prescribed in Incoterms 2010. |
| Notices GCC 8.1 | <p>Any notice shall be sent to the following addresses: For NamWater Ltd the address and the contact name shall be:</p> <p style="text-align: center;">Procurement Management Unit</p> <p>(Tel: +264 61 71 2015, E-mail: bids@namwater.com.na Private Bag 13389 Windhoek, Namibia</p> <p>For the Supplier, the address and contact name shall be: _____</p> |

| Subject and GCC clause reference | Special Conditions |
|--|---|
| Disputes GCC 10.2 | The rules of procedures for arbitration proceedings pursuant to GCC 10.2 shall be as follows: In the case of a dispute between the Purchaser and a Supplier, the dispute shall be arbitrated in accordance with Arbitration Act, 1965 (Act No. 42 of 1965). |
| Delivery and Documents GCC 13.1 | The Goods to be delivered within 8 weeks from the date of Purchase Order or Letter of Acceptance. Delivery will only be deemed complete if NamWater received the following documentation, certified by the Supplier: <ul style="list-style-type: none"> (a) signed delivery note; (b) Invoice |
| Price Adjustment GCC 15.1 | The price charge for the Goods supplied and the related Services performed “ shall not ” be adjustable. |
| Terms of Payment GCC 16.1 | The structure of payments shall be: full payment following delivery of the Supplies and submission of an invoice and the documents listed in clause 13.1 |
| Terms of Payment GCC 16.3 | Payments shall be made not later than thirty days after submission of an invoice and its certification by the Purchaser. Payments are processed only at the end of each month. Payment will only be made if all the delivered items are to specifications |
| Terms of Payment GCC 16.4 (a) | The price shall not be adjustable to the fluctuation in the rate of exchange. |
| Payment Period GCC 16.5 | The method and conditions of payments to be made to the Supplier under this Contract shall be as follows: <ul style="list-style-type: none"> i) On Acceptance: The Contract Price of goods received shall be paid no later than thirty (30) days of receipt of the Goods upon submission of an invoice (showing Purchaser’s name; the Procurement Reference number, description of payment and total amount, signed in original, stamped or sealed with the company stamp/seal) supported by the Acceptance Certificate issued by the Purchaser. |
| Performance Security GCC 18.1 | Not Applicable |

| Subject and GCC clause reference | Special Conditions |
|---|--|
| Discharge of Performance Security GCC 18.4 | Not Applicable |
| Packing GCC 23.2 | <p>The packing, marking and documentation within and outside the packages shall be:</p> <p>Addressed to NamWater and the Procurement reference No. clearly marked</p> <p>The packing of the materials shall be of sufficient quality and design to protect the equipment against any undue damage or stresses during transportation.</p> <p>All pipework shall be packaged and/or wrapped to appropriately protect the coatings from damage during transit. The supplier shall be required to touch-up any areas where the coating has been damaged during transit.</p> <p>The fasteners shall be packaged in suitable woven bags with appropriate labelling. The bags shall then be crated for transport and delivery. Each lot of fasteners and gaskets shall be crated separately.</p> |
| Insurance GCC 24.1 | Not Applicable |
| Transportation GCC 25 | The Goods shall be delivered: Delivery Duty Paid (DDP) |
| Inspection and Tests GCC 26. | The goods will be inspected to confirm conformity to required dimensions, standards and any other applicable requirements as stated in the bidding document. |
| Liquidated Damages GCC 27 | Liquidated damages for the whole contract are 0.5% per day. The maximum amount of liquidated damages for the whole contract is 10% of the final contract price. |
| Warranty GCC 28.3 | The warrantee period shall be 18 months from date of delivery. The Supplier shall rectify, free of charge, any defects developing under proper use and arising from faulty materials, faulty workmanship and deviations from specifications. |
| Repair and Replacement GCC 28.5 | The period for repair or replacement shall be shall be as soon as is reasonable practicable, but shall not exceed the offered delivery period. |

SCHEDULE 1**QUOTATION CHECKLIST SCHEDULE****Procurement Reference No.: G/RFQ/NW-006/2027**

| Description | Attached | Not Attached |
|---|----------|--------------|
| Quotation Letter | | |
| List of Goods and Price Schedule | | |
| Specification and Compliance Sheet | | |
| Evidences for conformity of Goods (Offered flange adapters and gaskets brochure or datasheet) | | |
| valid copy of company registration / founding statement. (certified by a Commissioner of Oath appointed in terms of the Justices of the Peace and Commissioners of Oaths Act.1963 (Act No. 16 of 1963)) | | |
| Original or certified copy of valid good Standing TAX Certificate; (certified by a Commissioner of Oath appointed in terms of the Justices of the Peace and Commissioners of Oaths Act.1963 (Act No. 16 of 1963)) | | |
| Valid good Standing Social Security Certificate; | | |
| A certified copy of a valid Affirmative Action Compliance Certificate, or proof from Employment Equity Commissioner that bidder is not a relevant employer, or exemption issued in terms of Section 42 of the Affirmative Action Act, 1998; (certified by a Commissioner of Oath appointed in terms of the Justices of the Peace and Commissioners of Oaths Act.1963 (Act No. 16 of 1963)) | | |
| Submit signed Bid-securing Declaration. | | |
| An undertaking on the part of the Bidder that the salaries and wages payable to its personnel in respect of this proposal are compliant to the relevant laws, Remuneration Order, and Award, where applicable and that it will abide to sub-clause 4.6 of the General conditions of Contract if it is awarded the contract or part thereof; and | | |
| Submit a minimum of one (1) reference letter from reputable entities whom the Bidder has supplied goods of similar nature in the last three (3) years, and handled successfully. | | |
| Supporting information / literature for all the items offered to substantiate compliance, where applicable. These documents must be from the manufacturer or an authorised manufacturer's representative. Representatives must provide an authorised letter from the manufacturer confirming their status. | | |

Disclaimer: The list defined above is meant to assist the Bidder in submitting the relevant documents and shall not be a ground for the bidder to justify its non-submission of major documents for its

quotation to be responsive. The onus remains on the Bidder to ascertain that it has submitted all the documents that have been requested and are needed for its submission to be complete and responsive.

NOTES :

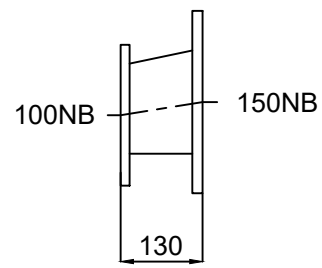

ITEM 1

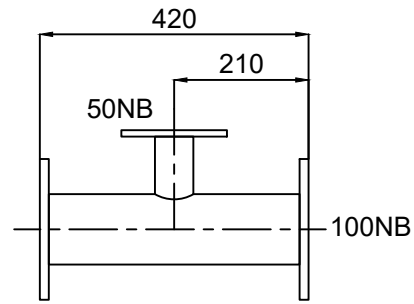

ITEM 2

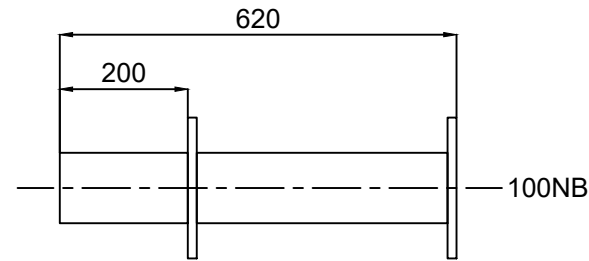

ITEM 3

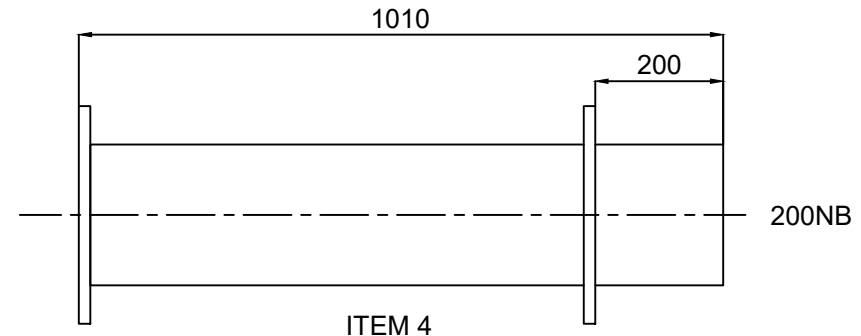

ITEM 4

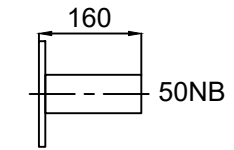

ITEM 9

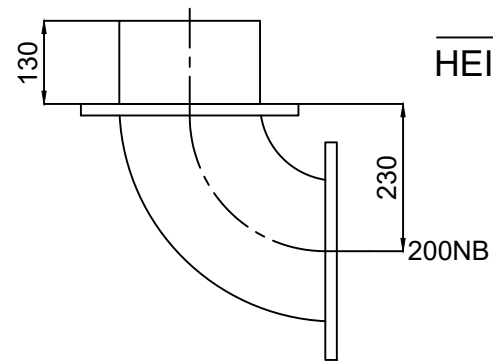

ITEM 5

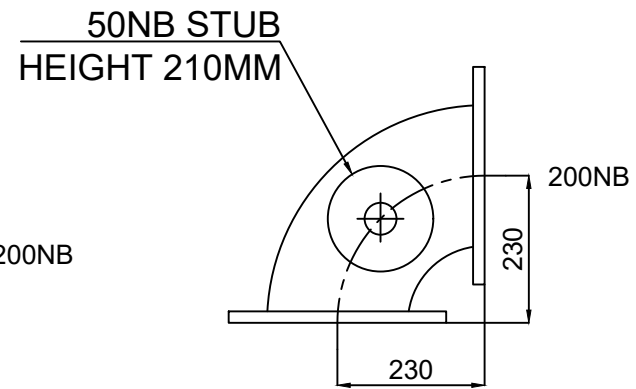

ITEM 6

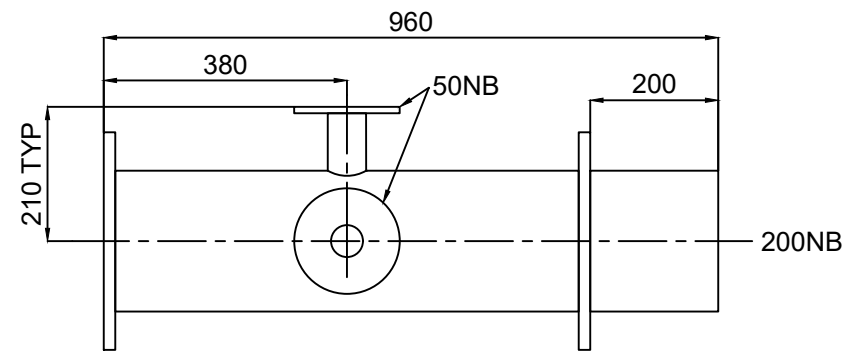

ITEM 7

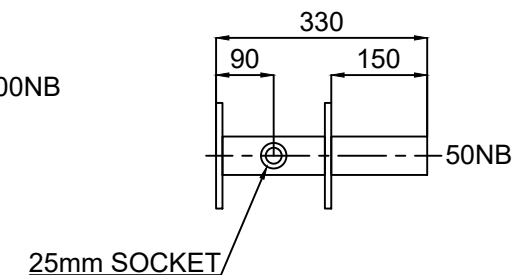

ITEM 10

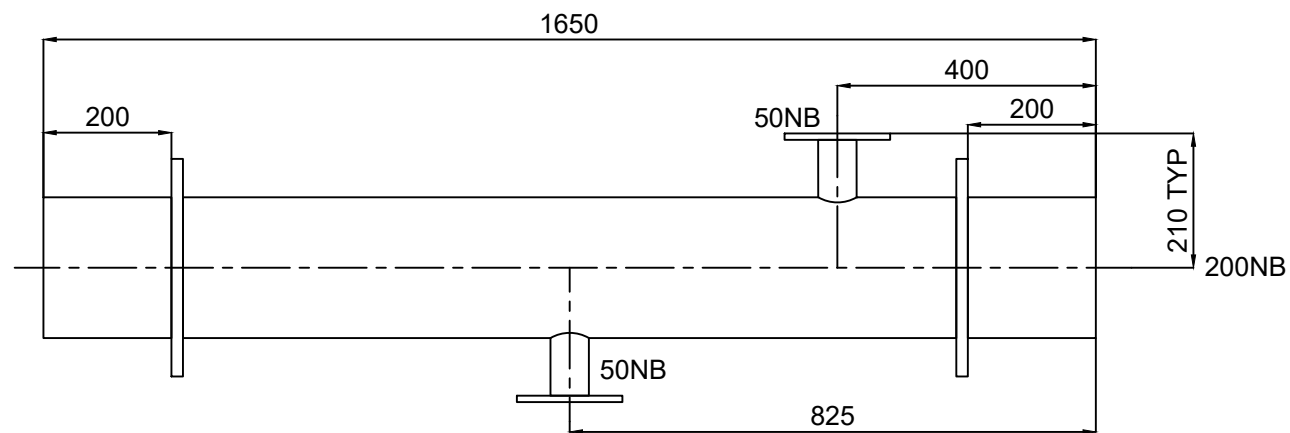

ITEM 8

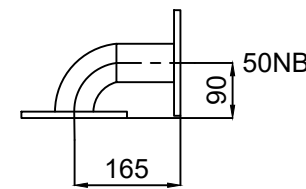

ITEM 11

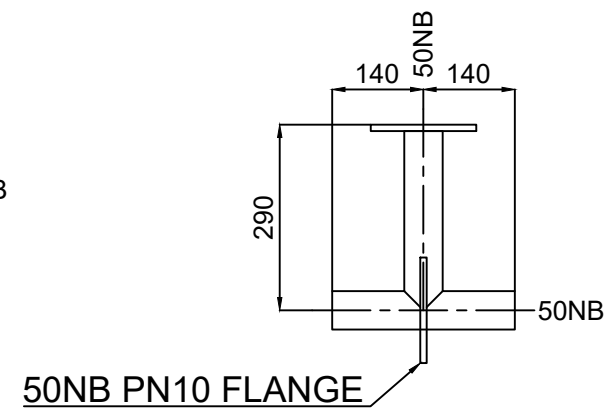

ITEM 12
TOP VIEW

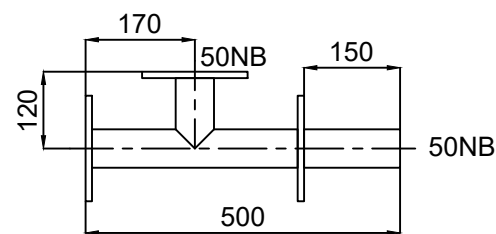

ITEM 13

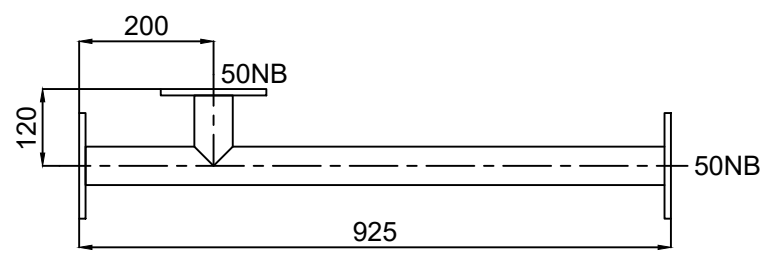

ITEM 14

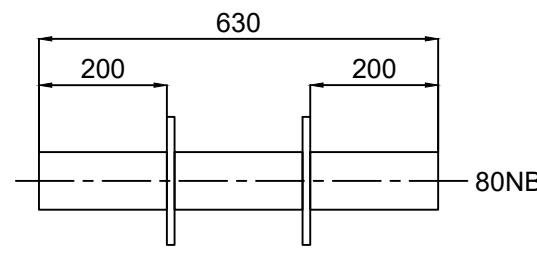

ITEM 17

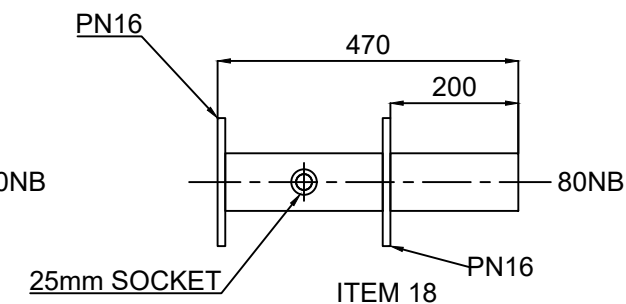

ITEM 18

| AMENDMENTS | DATE | BY |
|------------|------|----|
| | | |



SCHEME
GOBLENZ NEW RESERVOIR
PHASE 2

DRAWING

| SURVEYED | DRAWN | TRACED |
|----------------|----------------|----------------|
| DESIGNED CIVIL | DESIGNED ELEC. | DESIGNED MECH. |
| CHECKED CIVIL | CHECKED ELEC. | CHECKED MECH. |
| APPROVED CIVIL | APPROVED ELEC. | APPROVED MECH. |

GENERAL MANAGER ENGINEERING AND SCIENTIFIC SERVICES
SCALE SHEET NO.
1 OF 6

REGISTRATION NO.

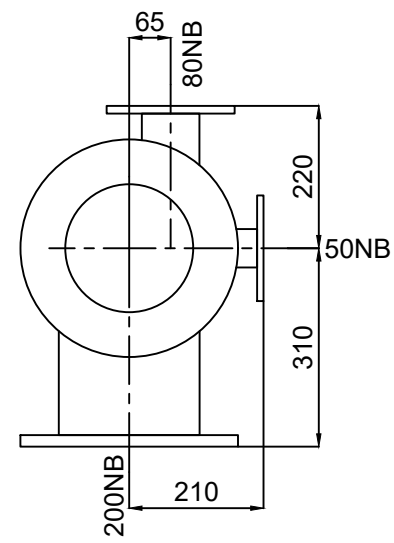

ITEM 15
SIDE VIEW

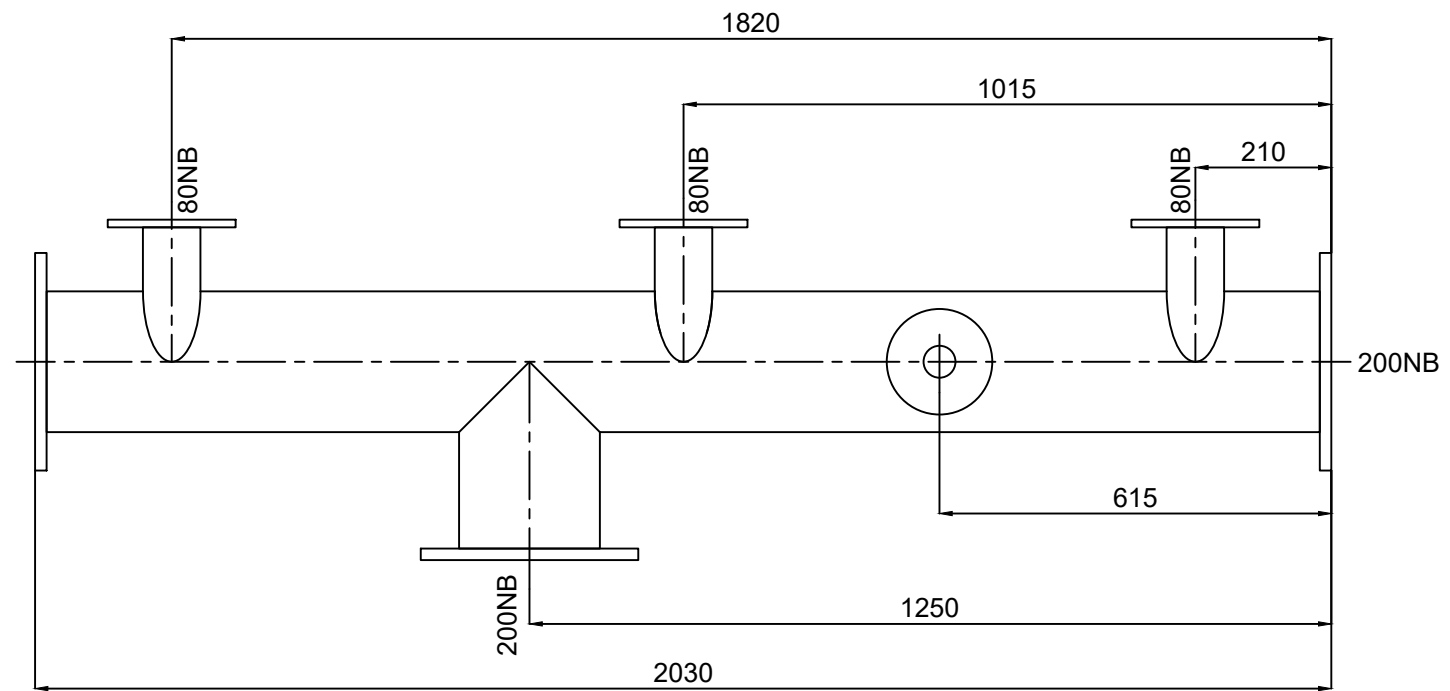

ITEM 15

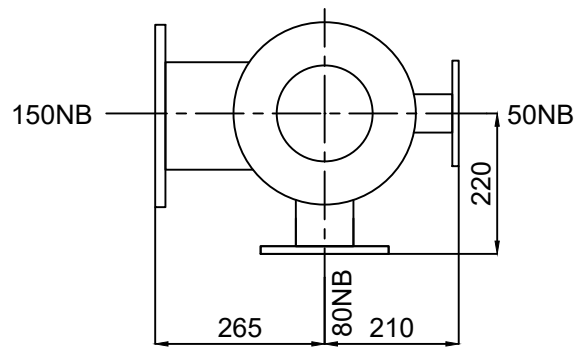

ITEM 16
SIDE VIEW

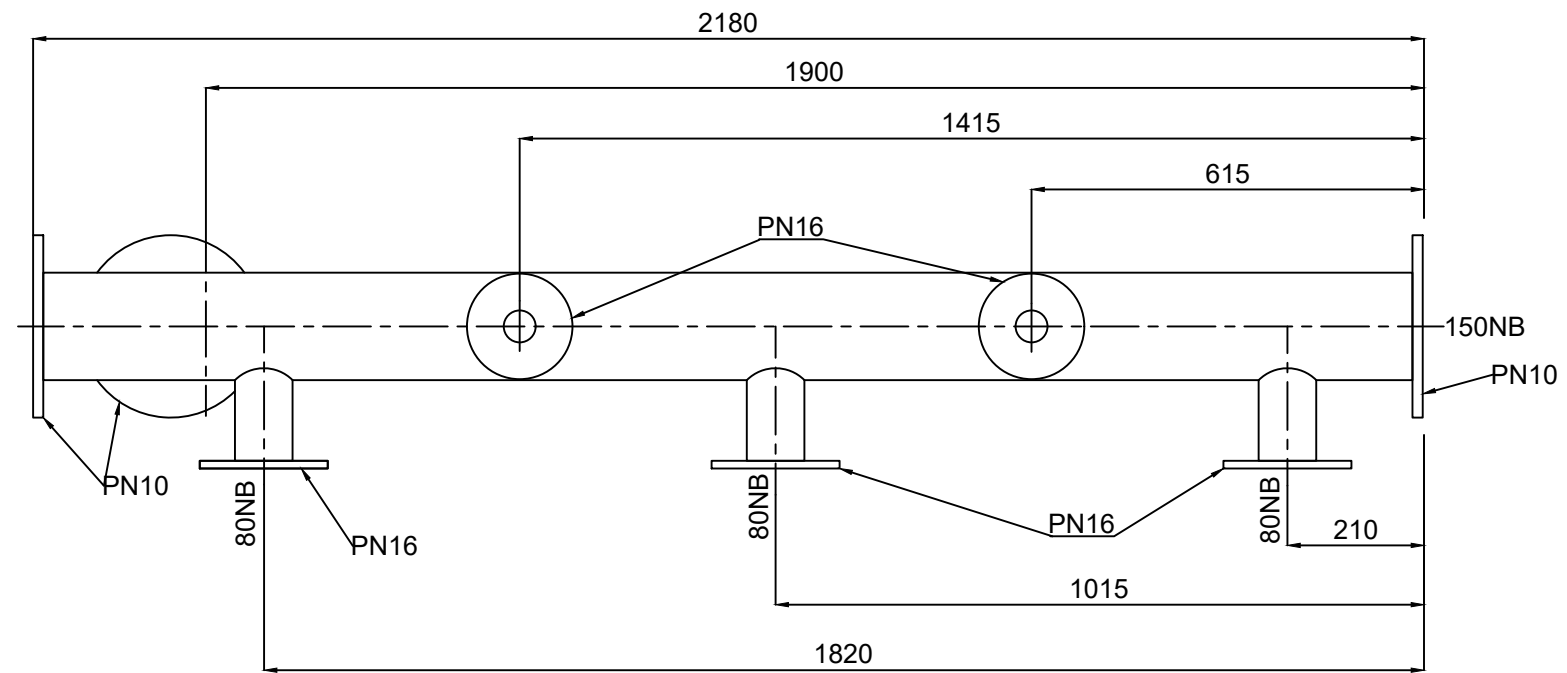

ITEM 16

NOTES :

| | | |
|--|--|--|
| | | |
|--|--|--|

| | | |
|------------|------|----|
| AMENDMENTS | DATE | BY |
|------------|------|----|



SCHEME
GOBLENZ NEW RESERVOIR
PHASE 2

DRAWING

| | | |
|----------------|----------------|----------------|
| SURVEYED | DRAWN | TRACED |
| DESIGNED CIVIL | DESIGNED ELEC. | DESIGNED MECH. |
| CHECKED CIVIL | CHECKED ELEC. | CHECKED MECH. |
| APPROVED CIVIL | APPROVED ELEC. | APPROVED MECH. |

| | |
|---|---------------------|
| GENERAL MANAGER ENGINEERING AND SCIENTIFIC SERVICES | |
| SCALE | SHEET NO. 2 OF 6 |
| REGISTRATION NO. | |

NOTES :

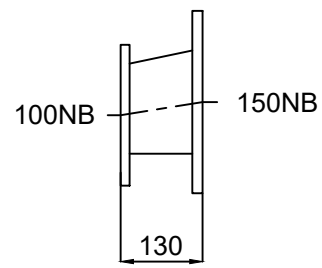

ITEM 1

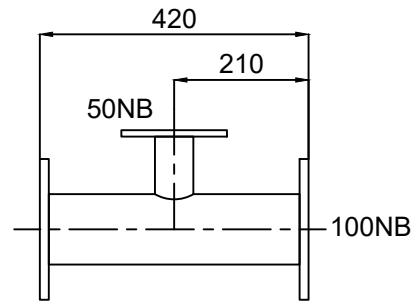

ITEM 2

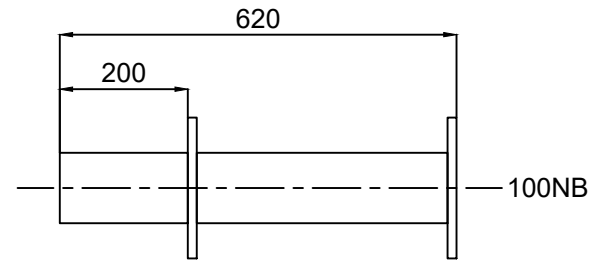

ITEM 3

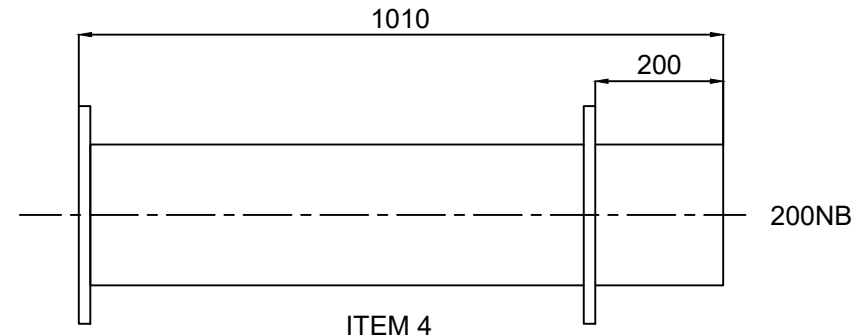

ITEM 4

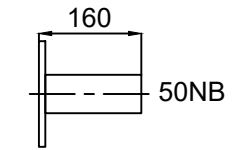

ITEM 9

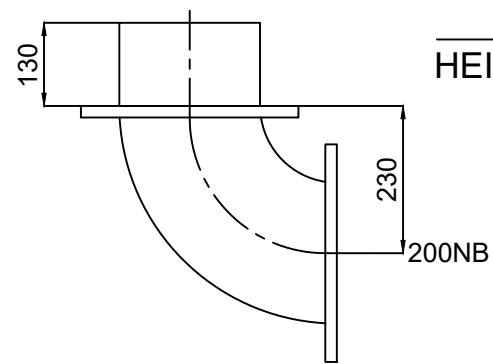

ITEM 5

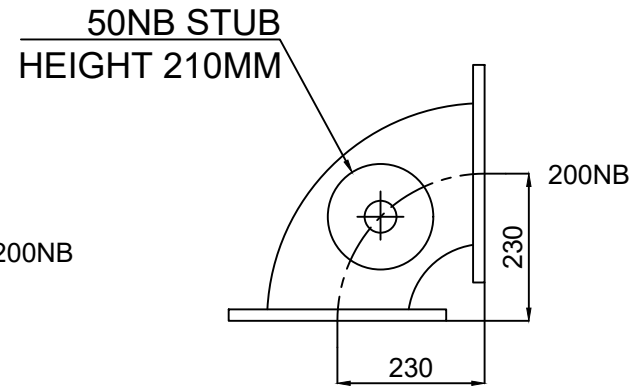

ITEM 6

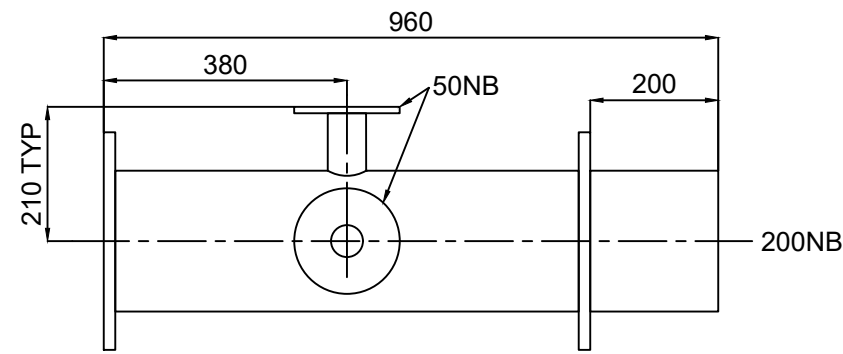

ITEM 7

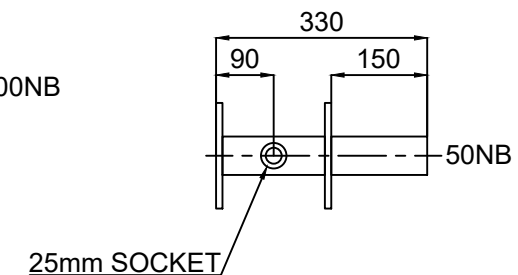

ITEM 10

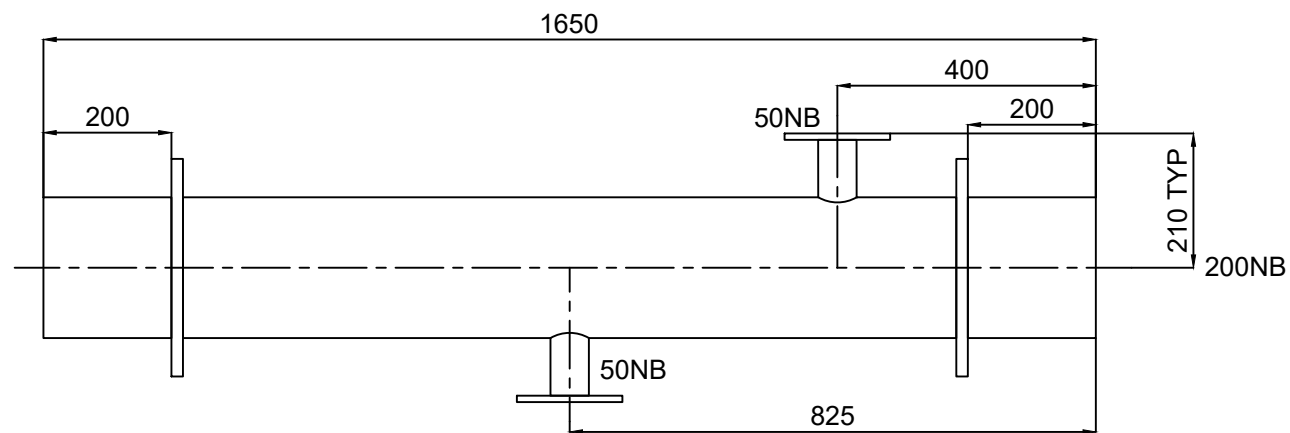

ITEM 8

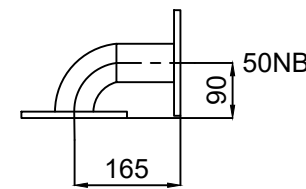

ITEM 11

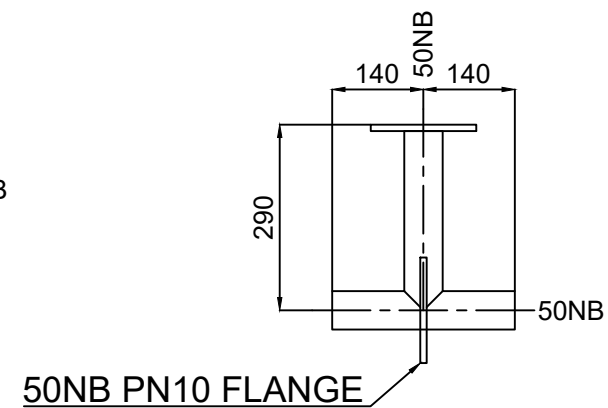

ITEM 12
TOP VIEW

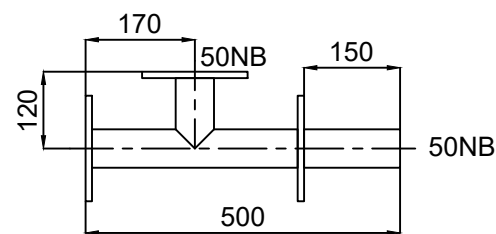

ITEM 13

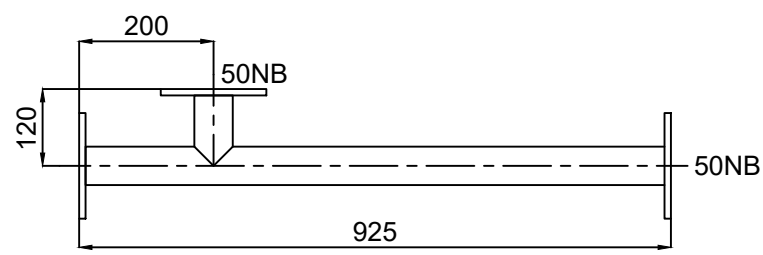

ITEM 14

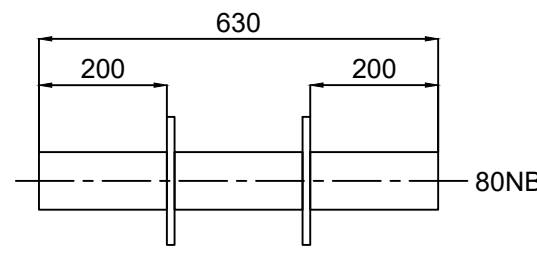

ITEM 17

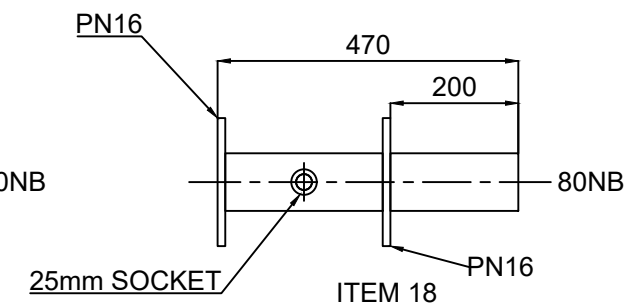

ITEM 18

| AMENDMENTS | DATE | BY |
|------------|------|----|
| | | |



SCHEME
GOBLENZ NEW RESERVOIR
PHASE 2

DRAWING

| SURVEYED | DRAWN | TRACED |
|----------------|----------------|----------------|
| DESIGNED CIVIL | DESIGNED ELEC. | DESIGNED MECH. |
| CHECKED CIVIL | CHECKED ELEC. | CHECKED MECH. |
| APPROVED CIVIL | APPROVED ELEC. | APPROVED MECH. |

GENERAL MANAGER ENGINEERING AND SCIENTIFIC SERVICES
SCALE SHEET NO. 3 OF 6
REGISTRATION NO.

LARGE PUMP BASE FRAME (4 OF 6)

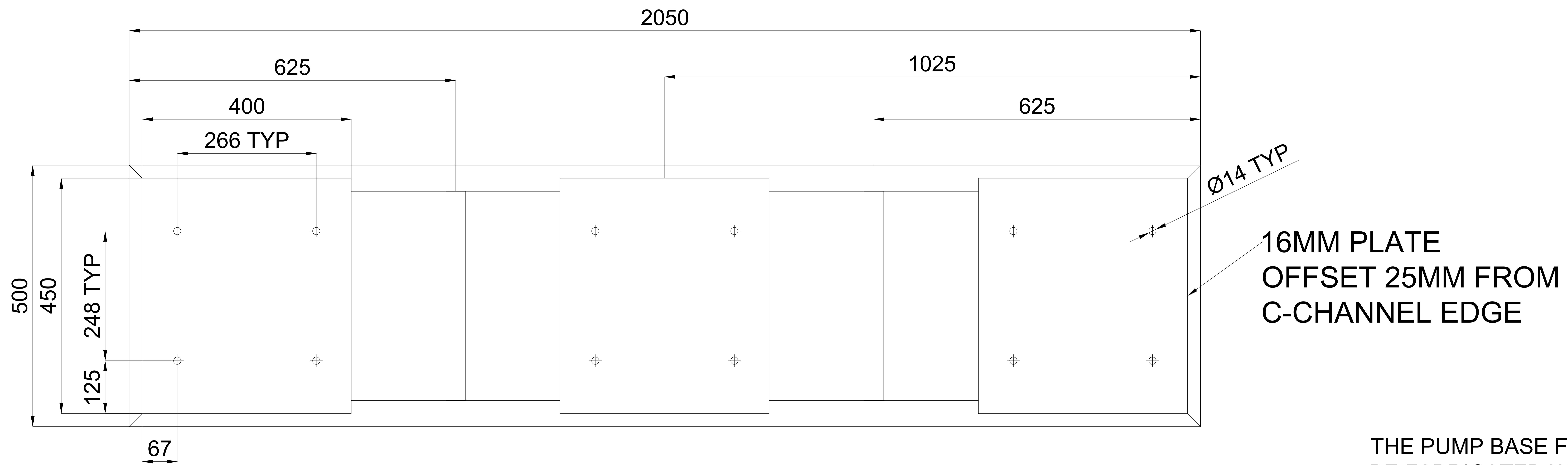

TOP VIEW

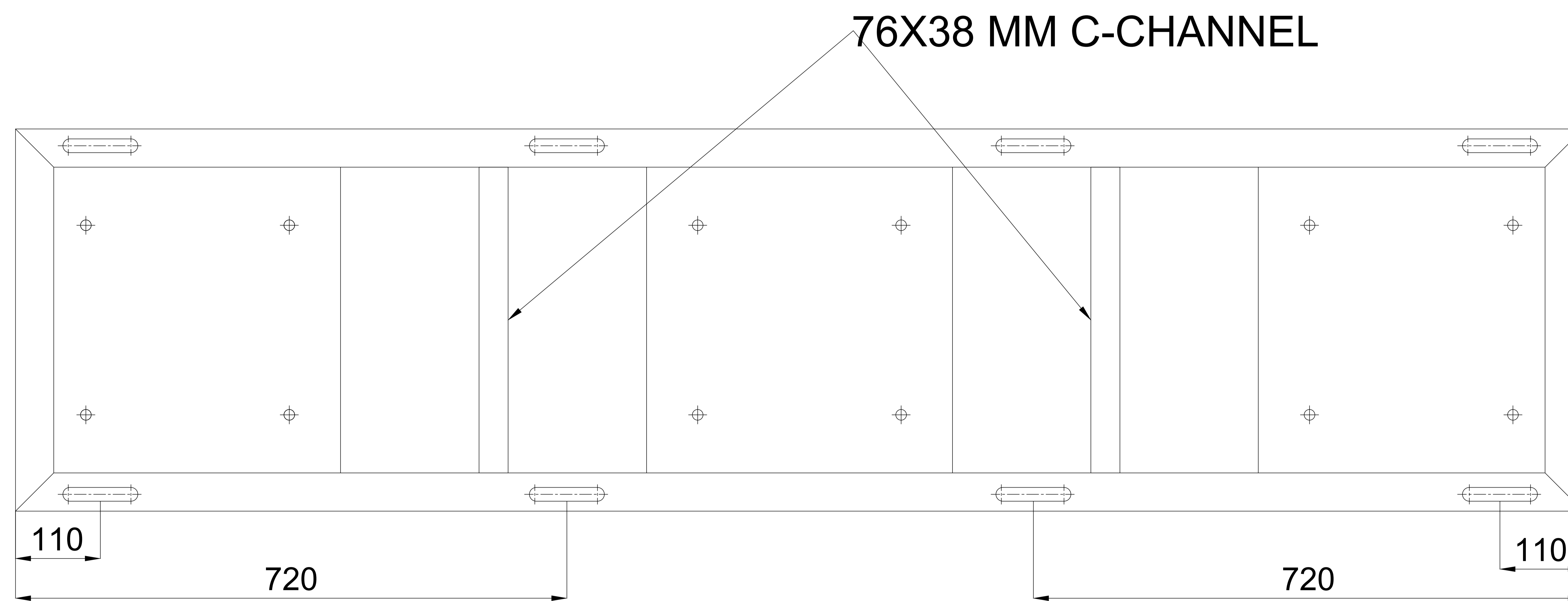

BOTTOM VIEW

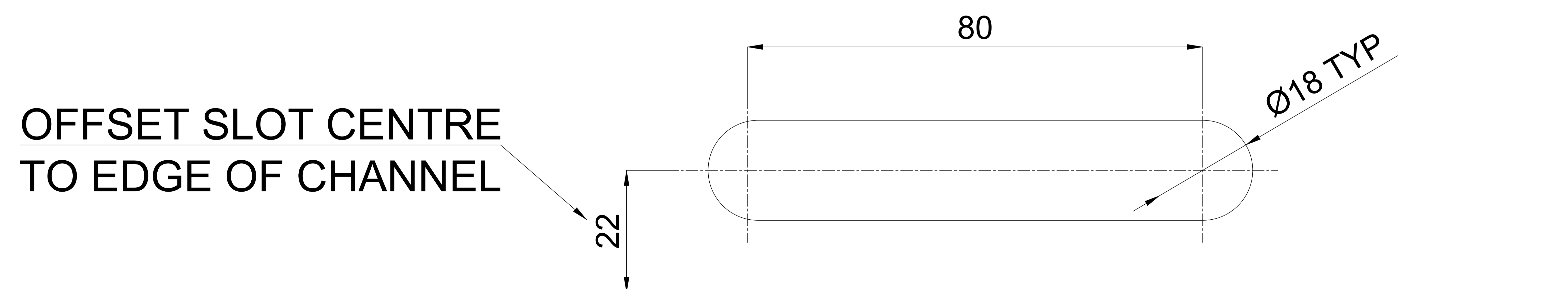

SLOT DETAIL

THE PUMP BASE FRAME SHALL
 BE FABRICATED WITH 3X 16MM
 PLATE WITH 4X Ø14 HOLES
 EACH.
 BELOW THE PLATE SHALL BE A
 FRAME OF 100X50 MM
 C-CHANNEL.
 THE 2 CROSS BRACING PIECES
 SHALL BE 76X38MM CHANNEL,
 AS INDICATED ON THE
 BOTTOM VIEW. THE
 C-CHANNELS SHALL OPEN
 OUTWARDS. THE CHANNELS
 SHALL HAVE MOUNTING SLOTS
 MACHINED INTO THE BOTTOM
 FLANGE AS PER THE BOTTOM
 VIEW.

MEDIUM PUMP BASE FRAME (5 OF 6)

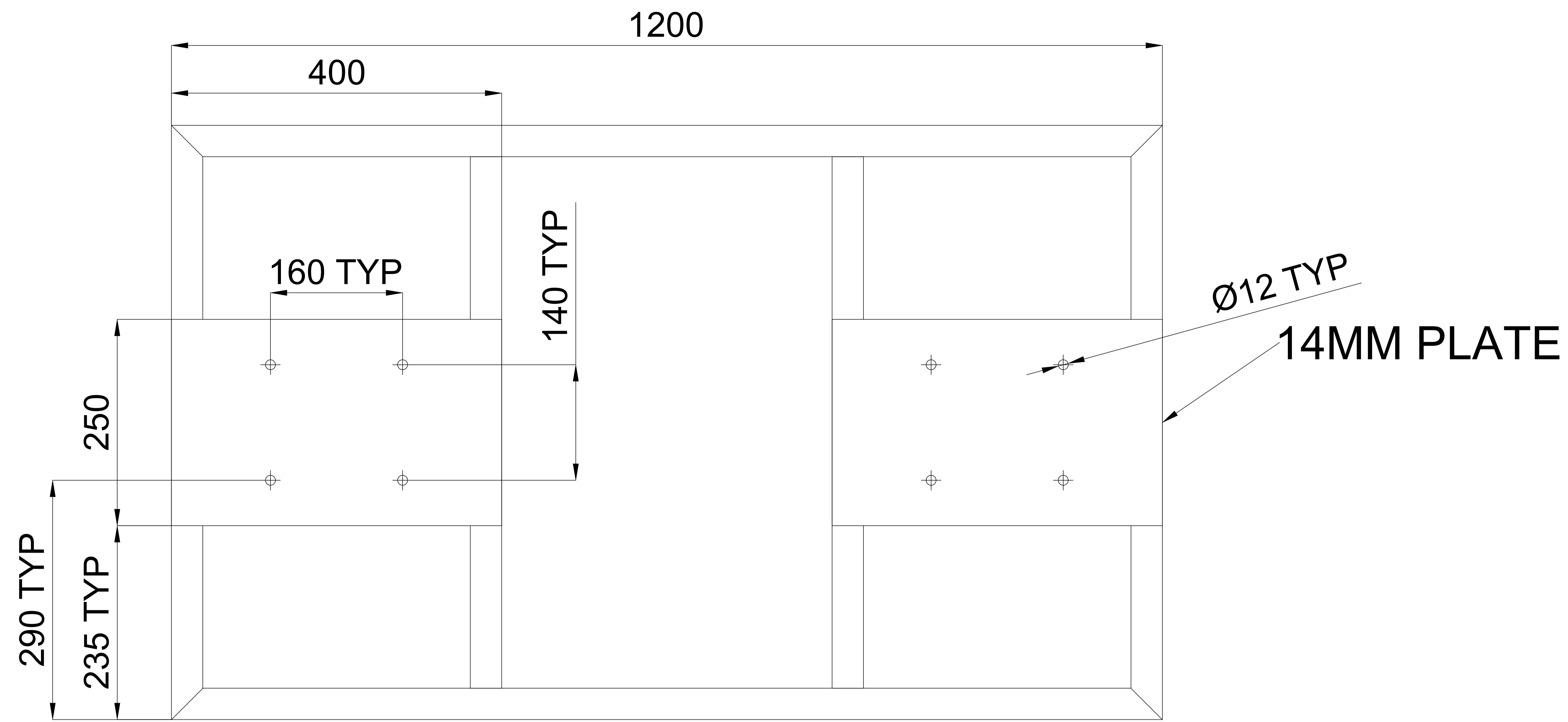

TOP VIEW

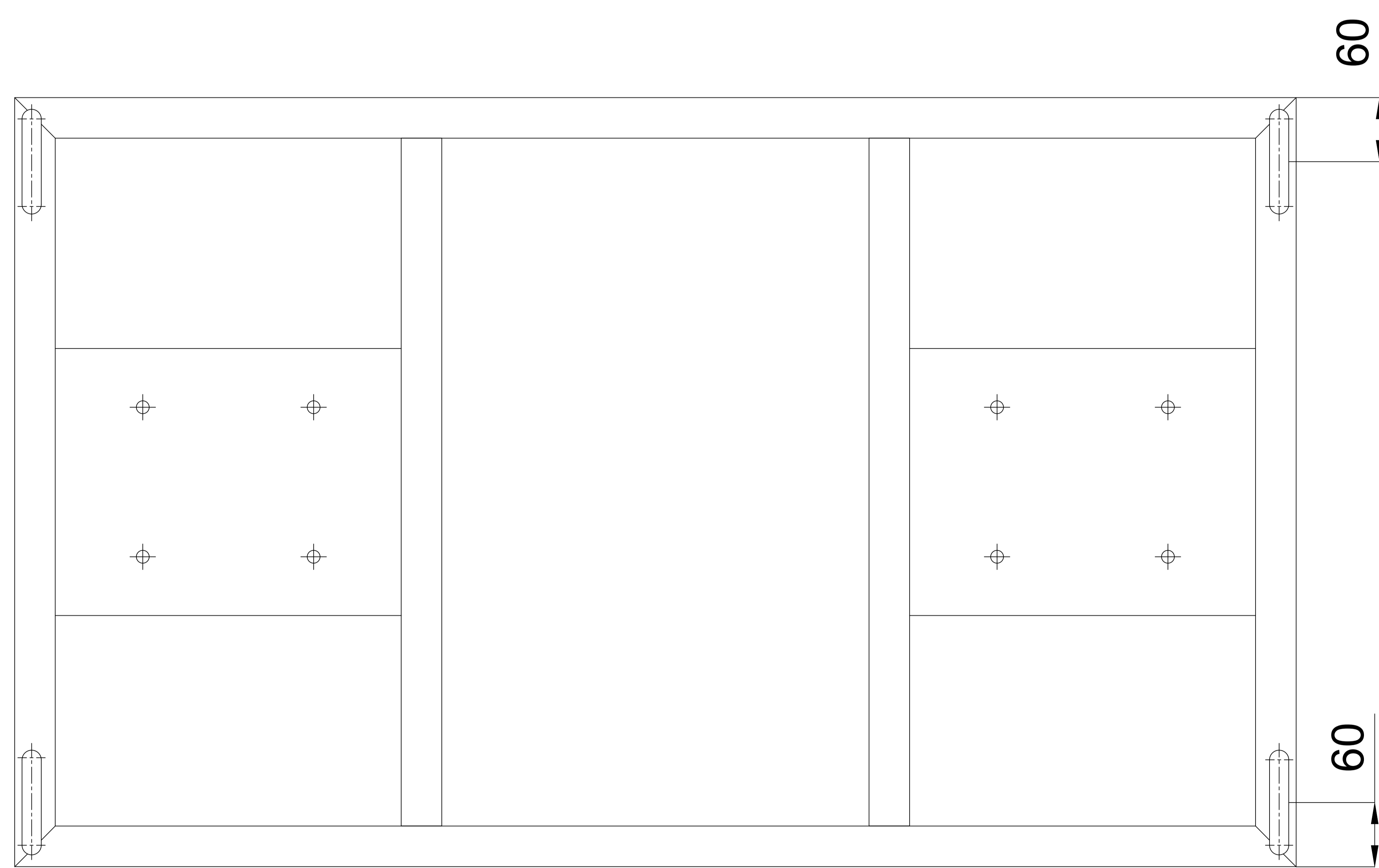

BOTTOM VIEW

THE PUMP BASE FRAME SHALL BE FABRICATED WITH 2X 14MM PLATE WITH 4X Ø12 HOLES EACH. BELOW THE PLATE SHALL BE A FRAME OF 76X38 MM C-CHANNEL. THE C-CHANNELS SHALL OPEN OUTWARDS. THE CHANNELS SHALL HAVE MOUNTING SLOTS MACHINED INTO THE BOTTOM FLANGE AS PER THE BOTTOM VIEW.

OFFSET SLOT CENTRE TO EDGE OF CHANNEL

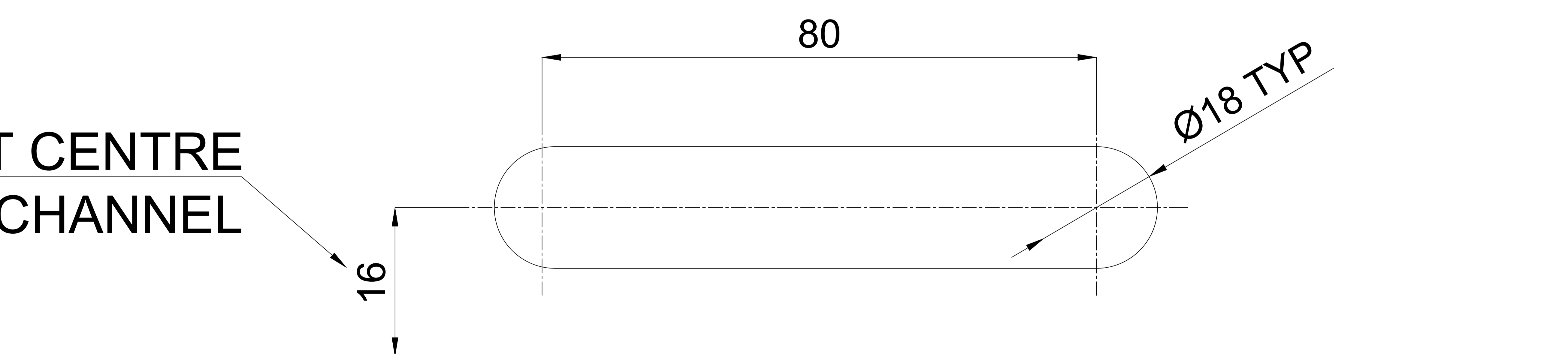

SLOT DETAIL

SMALL PUMP BASE FRAME (6 OF 6)

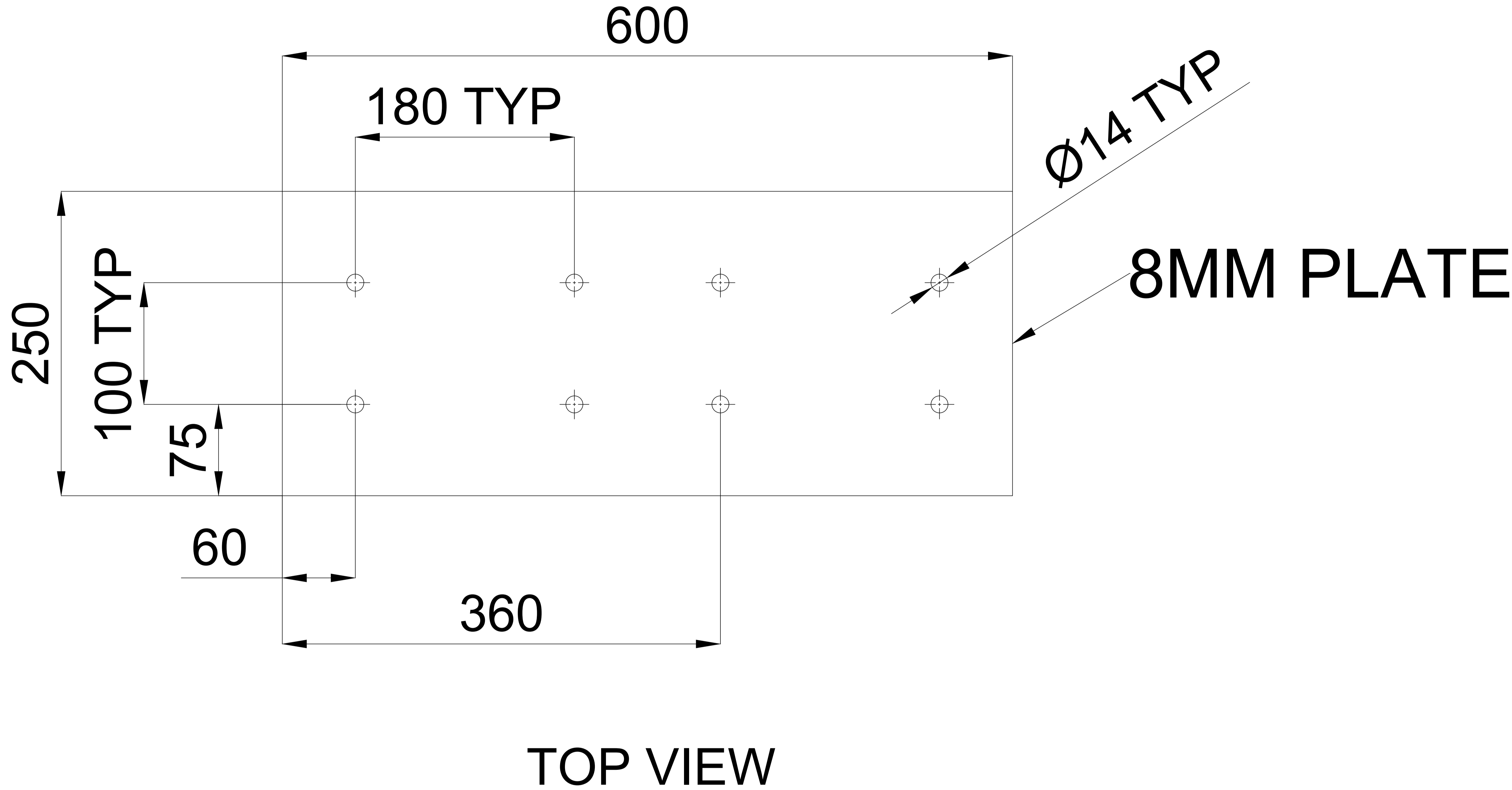

THE PUMP BASE FRAME SHALL BE FABRICATED WITH AN 8MM PLATE WITH 8X Ø14 HOLES. BELOW THE PLATE SHALL BE 76X38 MM C-CHANNEL. SIDE C-CHANNELS SHALL OPEN OUTWARDS. THESE CHANNELS SHALL HAVE 4X Ø18 HOLES DRILLED THROUGH THE BOTTOM FLANGE.

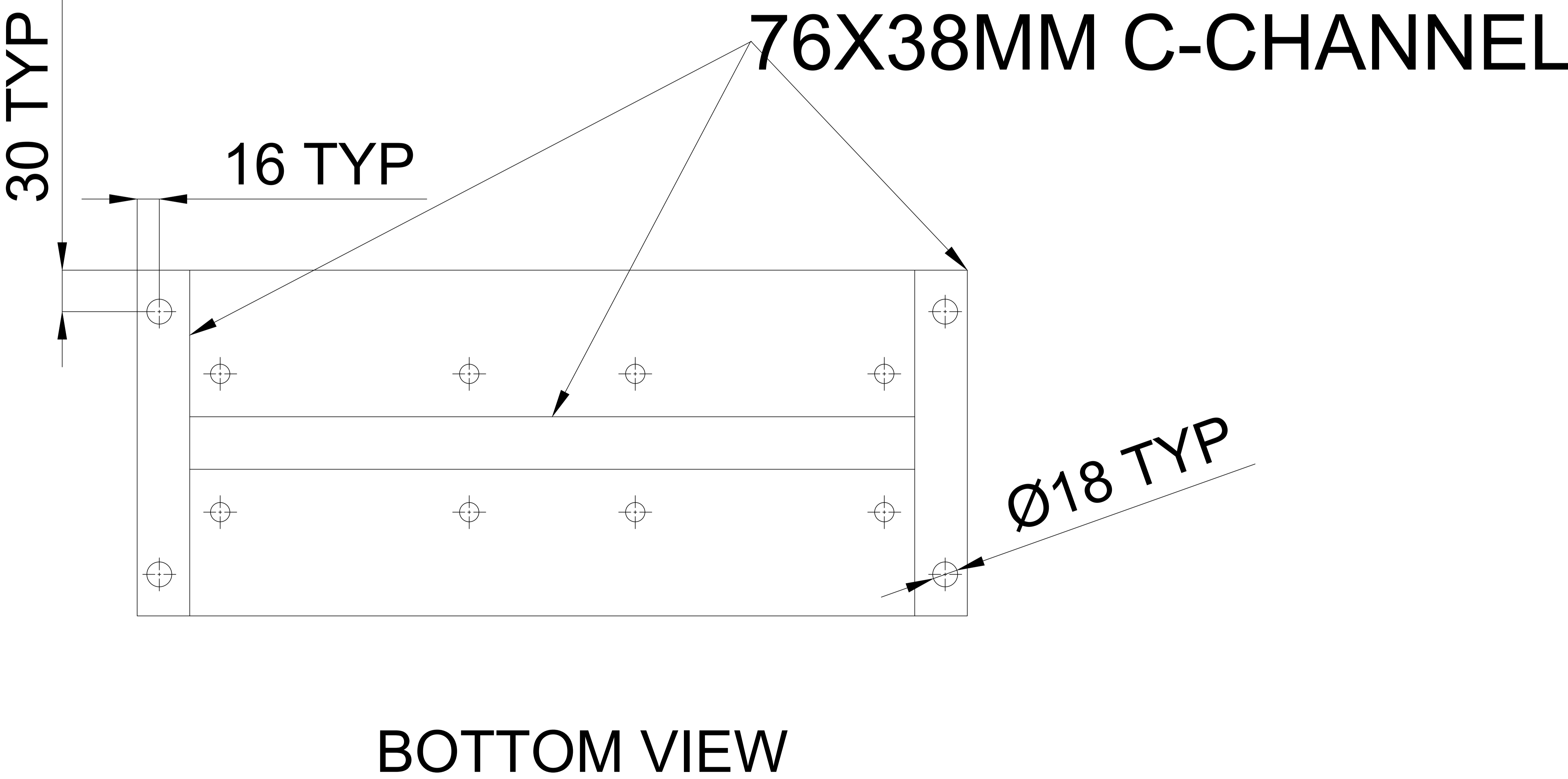

LOT 2: PIPEWORK RUACANA

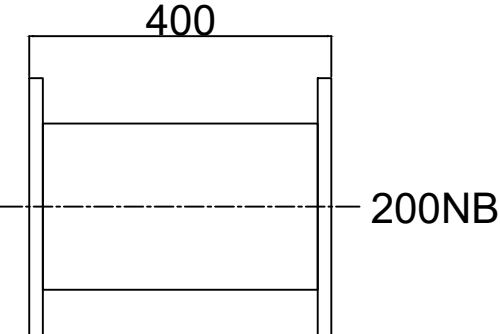

ITEM 1

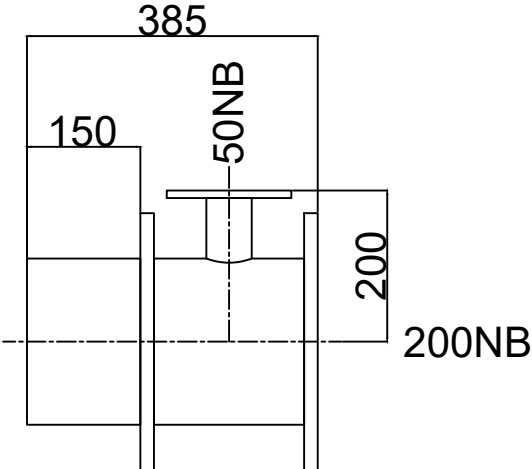

ITEM 2

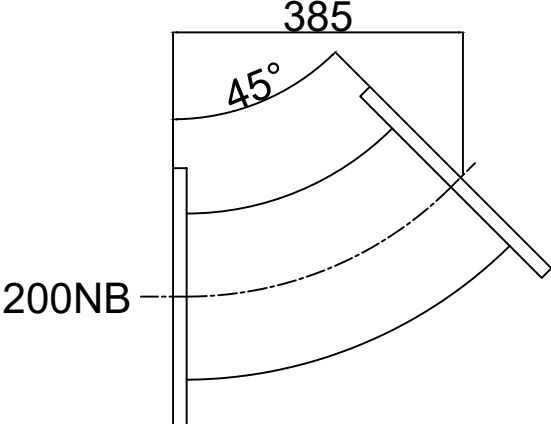

ITEM 3

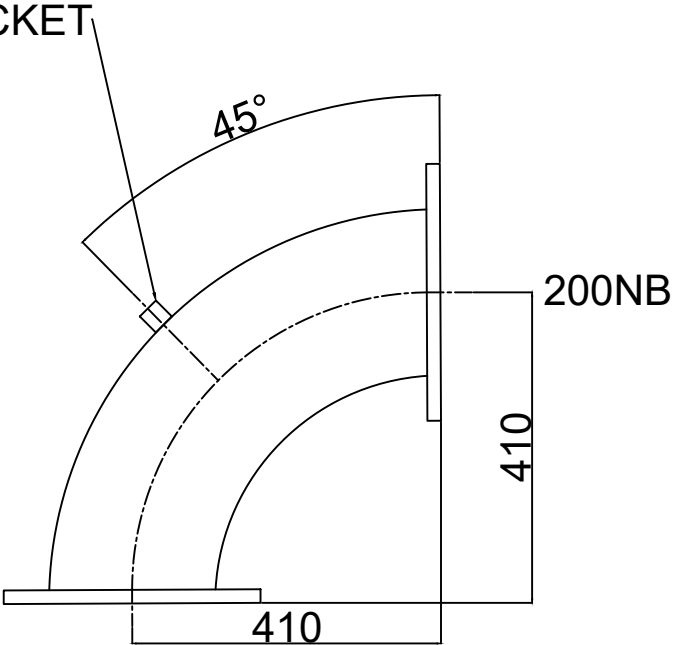

ITEM 4

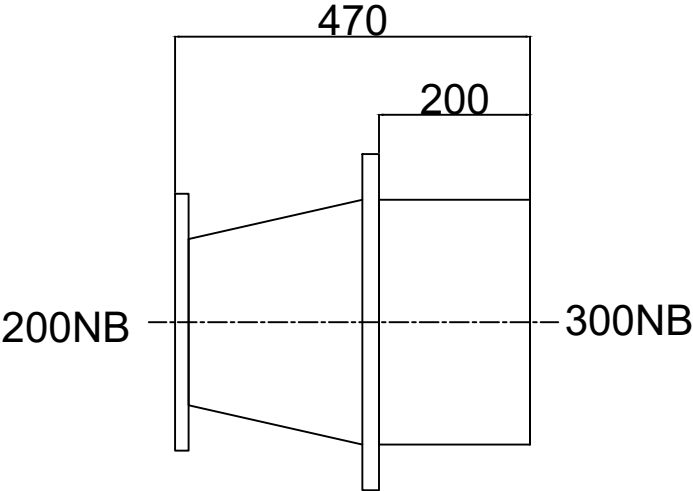

ITEM 5

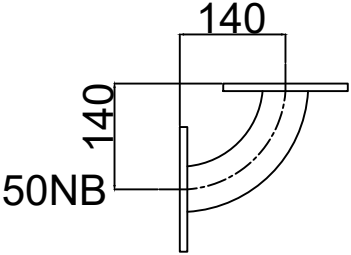

ITEM 6

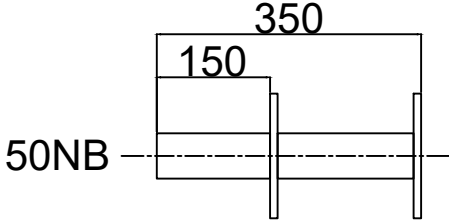

ITEM 7

Lot 3: Pipework Tsumkwe

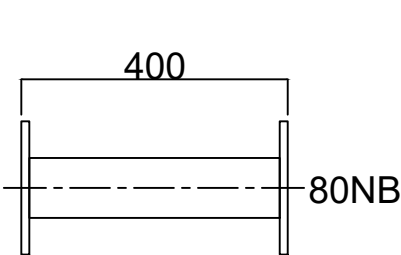

ITEM 1

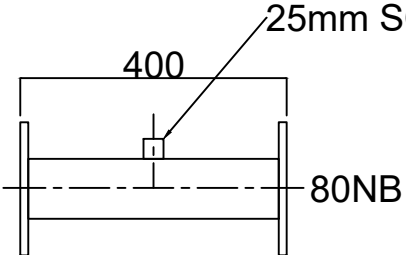

ITEM 2

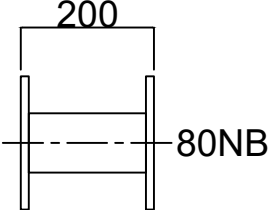

ITEM 3

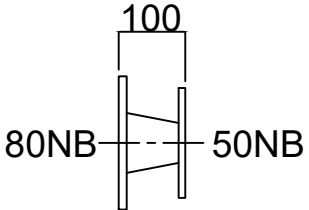

ITEM 4

LOT 4:
SHEET 1 OF 2

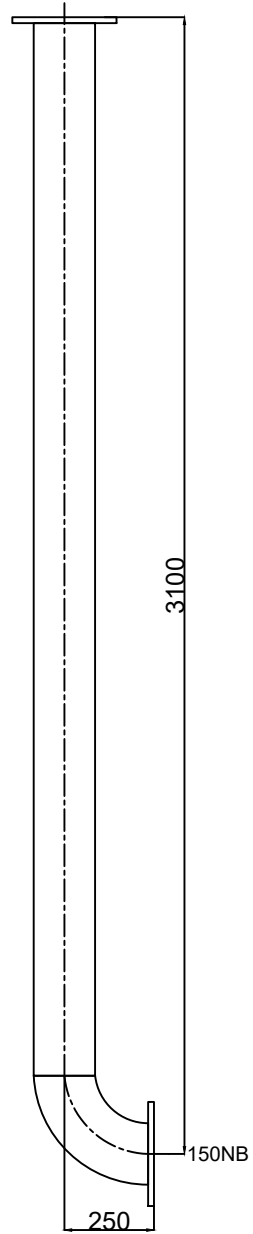

ITEM 1

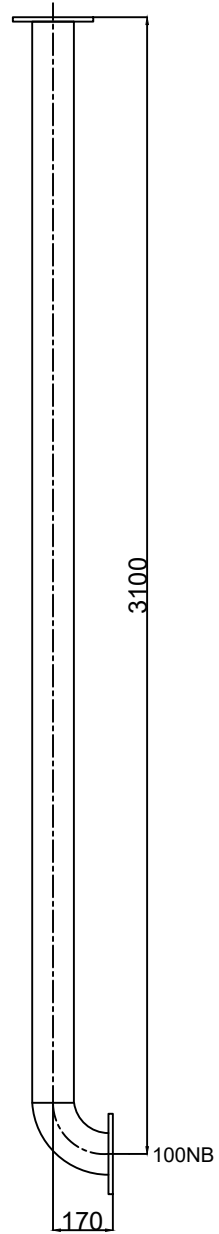

ITEM 2

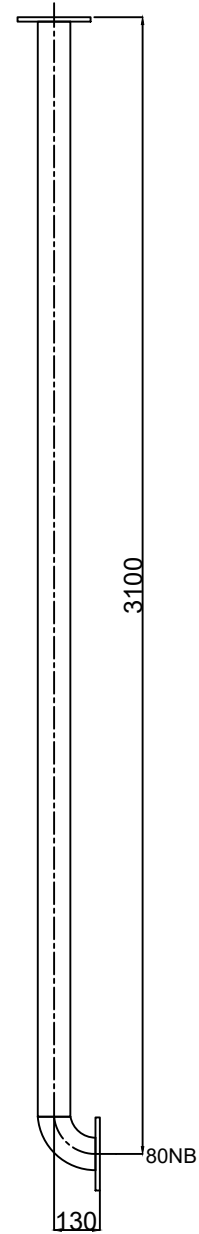

ITEM 3

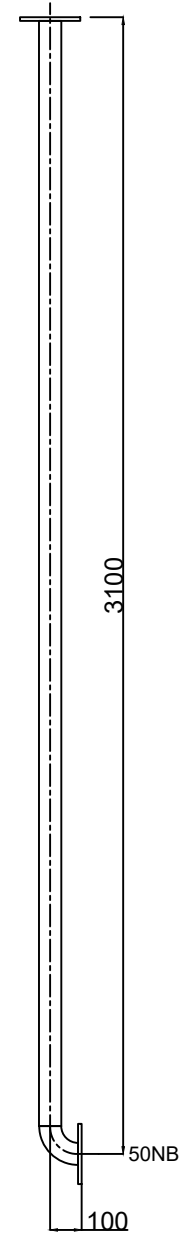

ITEM 4

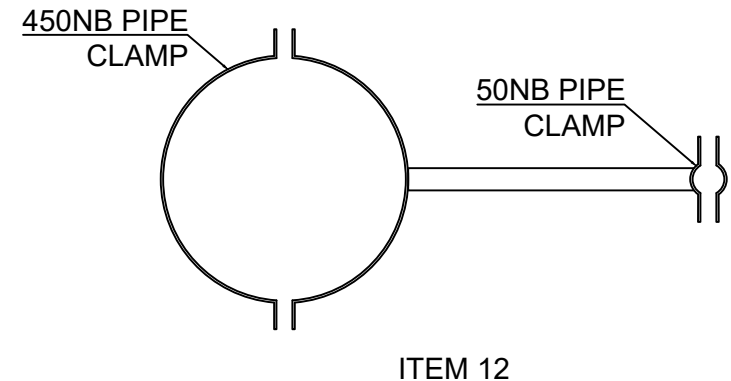
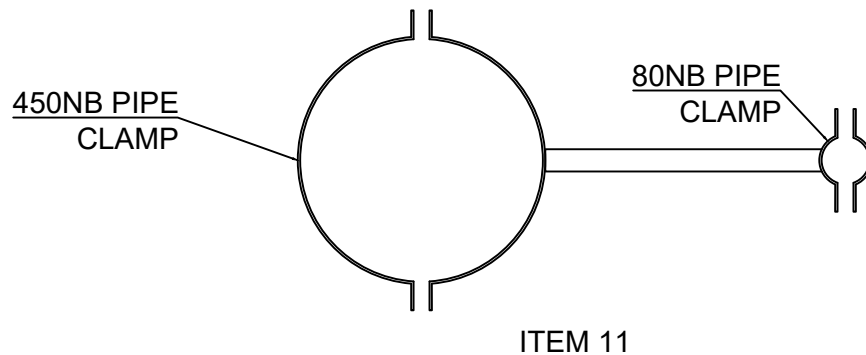
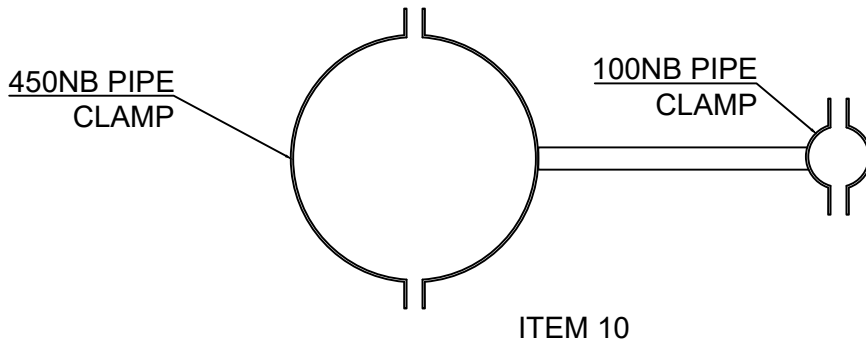
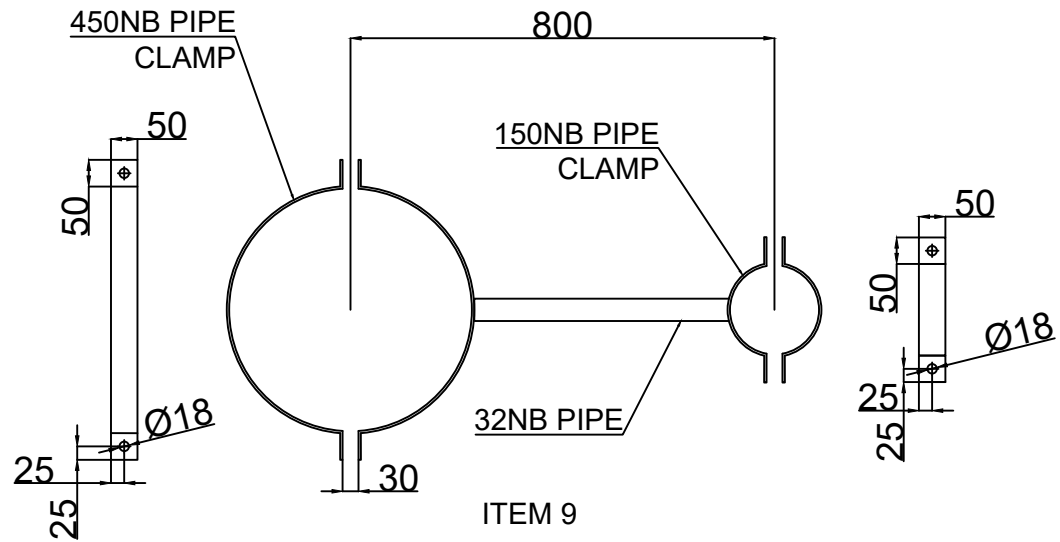

EACH PIPE CLAMP (ITEMS 9 TO 12) IS USED TO CONNECT TWO PIPES. ALL CLAMPS FEATURE A 450NB CLAMP ON ONE SIDE AND EITHER A 150NB, 100NB, 80NB OR 50NB CLAMP ON THE OTHER SIDE. ALL CLAMPS (ITEM 9 TO 12) HAVE AN 800MM CENTER-TO-CENTER DISTANCE. THE CLAMPS ARE MADE OF THE RELEVANT NB PIPE SECTIONS WITH 50MM X 50MM X 5MM TABS WELDED TO THE SECTIONS. THE TABS HAVE 18MM HOLES IN THE MIDDLE. THE TWO CLAMPS ARE CONNECTED BY A 32NB PIPE. THE CONNECTION POINT BETWEEN THE 32NB PIPE AND THE CLAMPS SHALL BE CONTINUOUSLY WELDED ALONG THE MATING SURFACES.