



Request for Sealed Quotations for Goods

Supply & Delivery of Steel Pipe Specials, Flexible Couplings, Fasteners and Gaskets for the Ombalantu Raw Water Strainers.

Procurement Reference No: G/RFQ/NW-008/2027

Name of Bidder		
Contact Person		
E-mail Address		
Postal Address		
Total Amount (Excl. VAT)		
Contact Phone number	Work:	Mobile:

Documents must be posted / delivered to:

The Quotation/Bid Box

Att: Procurement Management Unit (+264 61 71 2015, bids@namwater.com.na)

Namibia Water Corporation Ltd.

Private Bag 13389

176 Iscor Street, Aigams Building

Windhoek

Closing Date: Thursday, 23 April 2026 at 11h00

NO LATE BIDS WILL BE ACCEPTED!

NOTICE TO BIDDERS

- Please take note of initializing all pages of the standard bidding document and initial all the supporting documents including company profiles, brochures, etc.**
- Take note to sign all relevant pages as stipulated in the bidding standard document.**

Copies of documents not certified by a Commissioner of Oath appointed in terms of the Justices of the Peace and Commissioners of Oaths Act.1963 (Act No. 16 of 1963) will not be accepted



Namibia Water Corporation Ltd.
Private Bag 13389, Windhoek, Namibia
Tel: +264 61 71 2066
Fax: +264 61 21 0741

Letter of Invitation

Name and Address of Bidder _____

Procurement Reference Number: G/RFQ/NW-008/2027

09 April 2026

Dear Sir/Madam

Supply & Delivery of Steel Pipe Specials, Flexible Couplings, Fasteners and Gaskets for the Ombalantu Raw Water Strainers.

NamWater invites you to submit your best quote for the items described in detail hereunder. Any resulting contract shall be subject to the terms and conditions referred to in the document. Queries, if any, should be addressed to Procurement Management Unit E-mail: bids@namwater.com.na, Private Bag 13389 Windhoek, Namibia.

Please prepare and submit your Bid in accordance with the instructions given or inform the undersigned if you will not be submitting a quotation.

Yours faithfully,

Procurement Management Unit

Initials.....

SECTION I: INSTRUCTIONS TO BIDDERS

1. Rights of Public Entity

NamWater Ltd reserves the right:

- (a) to split the contract as per the lowest evaluated cost per item, and
- (b) to accept or reject any quotation; and
- (c) to cancel the quotation process and reject all quotations at any time prior to contract award.

2. Preparation of Quotations

You are requested to quote for the items mentioned in Section III by completing, signing and returning:

- (a) the Quotation Letter in Section II;
- (b) the List of Goods and Price Schedule Section III;
- (c) the Specifications and Compliance Sheet in Section V; and
- (d) any other attachment deemed appropriate.

You are advised to carefully read the complete bidding document, including the Special Conditions of Contract in Section VII, before preparing your quotation. The standard forms in this document may be retyped for completion but the Bidder is responsible for their accurate reproduction.

3. Validity of Quotations

The Quotation validity period shall be **90** days from the date of submission deadline.

The tenderer shall initial each page after having read and completed this document. Any alterations made to any of the information contained in this document shall also be initialled.

4. Eligibility Criteria

To be eligible to participate in this Quotation exercise, you should:

- (a) Have a certified copy (certified by a Commissioner of Oath appointed in terms of the Justices of the Peace and Commissioners of Oaths Act.1963 (Act No. 16 of 1963)), of a **VALID** company Registration Document;
- (b) Have an original or a certified copy (certified by a Commissioner of Oath appointed in terms of the Justices of the Peace and Commissioners of Oaths Act.1963 (Act No. 16 of 1963)), of a valid Good Standing Tax Certificate, as certified by the Commissioner of Oath.
- (c) Have a valid good Standing Social Security Certificate,
- (d) Have a valid certified copy (certified by a Commissioner of Oath appointed in terms of the Justices of the Peace and Commissioners of Oaths Act.1963 (Act No. 16 of 1963)), of Affirmative Action Compliance Certificate, proof from Employment Equity Commissioner that bidder is not a relevant employer, or exemption issued in terms of Section 42 of the Affirmative Action Act, 1998 or a valid certified copy of the original document, as certified by the Commissioner of Oath;

Initials.....

- (e) Submit signed Bid-securing Declaration.
- (f) An undertaking on the part of the Bidder that the salaries and wages payable to its personnel in respect of this proposal are compliant to the relevant laws, Remuneration Order, and Award, where applicable and that it will abide to sub-clause 4.6 of the General conditions of Contract if it is awarded.
- (g) Submit supporting literature to substantiate compliance. **These documents must be from the manufacturer or an authorized manufacturer's representative of the offered goods. Representatives must provide an authorization letter from the manufacturer confirming their status.**
- (h) A Bidder that is under a declaration of ineligibility by the Government of Namibia in accordance with applicable laws at the date of the deadline for bid submission or thereafter, shall be disqualified.

Bids from service providers appearing on the ineligibility lists of African Development Bank, Asian Development Bank, European Bank for Reconstruction and Development, Inter-American Development Bank Group and World Bank Group shall be rejected.

Links for checking the ineligibility lists are available at:

- Republic of Namibia, Procurement Policy Unit
<https://egp2.gov.na/forms/SearchSuspendedBidders.jsf>
- African Development Bank
<https://www.afdb.org/en/projects-operations/debarment-and-sanctions-procedures>
- Asian Development Bank
<http://lnadbg4.adb.org/oga0009p.nsf/sancALLPublic?OpenView&count=999>
- European Bank for Reconstruction and Development
<http://www.ebrd.com/pages/about/integrity/list.shtml>
- Inter-American Development Bank Group
<http://www.iadb.org/en/topics/transparency/integrity-at-the-idb-group/sanctioned-firms-and-individuals,1293.html>
- World Bank Group
<http://www.worldbank.org/en/projects-operations/procurement/debarred-firms>

5. Bid Securing Declaration

Bidders are required to subscribe to a Bid Securing Declaration for this procurement process.

6. Delivery

The Goods are to be delivered within **4 weeks** from the date of Purchase Order or Letter of Acceptance.

Deviation in delivery period **shall not be accepted**.

6.1. All items shall be delivered to 176 Iscor street Namwater at the Aigams Building, Northern Industrial Area in Windhoek.

Initials.....

6.2. Delivery will only be considered to be complete once all equipment and documentation have been delivered, inspected and found to be in accordance with the specifications.

7. Sealing and Marking of Quotations

Quotations should be sealed in a single envelope, clearly marked with the Procurement Reference Number, addressed to NamWater with the Bidder's name and contact information at the back of the envelope.

8. Submission of Quotations

Quotations should be deposited in the Quotation/Bid Box located at Namibia Water Corporation Ltd Head office, Private Bag 13389, 176 Iscor Street, Aigams Building, Windhoek, not later than **Thursday, 23 April 2026 at 11h00**. Offers by post or hand delivered should reach Private Bag 13389 by the same date and time at latest. Late Offers will be rejected.

Offers received by e-mail will not be considered.

9. Opening of Quotations

Quotations will be opened internally by NamWater immediately after the closing time referred to in instruction 8 above. A record of the Quotation Opening stating the name of the bidders, the amount quoted, the presence or absence of a Bid Security/Bid Securing Declaration, will be posted on the website of the Public Entity and available to any bidder on request within three working days of the Opening.

10. Evaluation of Quotations

NamWater shall have the right to request for clarifications in writing during evaluation. Offers that are substantially responsive shall be compared on the basis of price or ownership cost, subject to Margin of Preference where applicable, to determine the lowest evaluated quotation.

11. Technical Compliance

Bidders shall submit along with their quotations documents, catalogues and any other literature to substantiate compliance with the required specifications and to qualify deviations if any with respect to NamWater's requirements.

The Specifications, Performance Requirements and Compliance Sheet details the minimum specifications of the goods/items to be supplied. The specifications have to be met but no credit will be given for exceeding the specifications.

12. Prices and Currency of Payment

Prices shall be fixed in Namibian Dollars.

13. Margin of Preference

Not Applicable

14. Award of Contract

The Bidder having submitted the lowest evaluated responsive quotation and qualified to supply the goods/items and related services shall be selected for award of contract. Award

Initials.....

of contract shall be by issue of a Purchase Order/Letter of Acceptance in accordance with terms and conditions contained in Section VI: Contract Agreement and General Conditions of Contract.

Partial award of complete Items will be allowed.

15. Notification of Award and Debriefing

The Public Entity shall after award of contract promptly inform all unsuccessful bidders in writing of the name and address of the successful bidder and the contract amount and post a notice of award on its website within seven days. Furthermore, the Public Entity shall attend to all requests for debriefing made in writing within 7 days of the unsuccessful bidders being informed of the award.

SECTION II: QUOTATION LETTER

(to be completed by Bidders)

[Complete this form with all the requested details and submit it as the first page of your quotation with the Price list and documents requested above. A signature and authorisation on this form will confirm that the terms and conditions of the RFQ prevail over any attachments. **If your quotation is not authorised, it will be rejected.**]

Quotation addressed to:	Namibia Water Corporation Ltd
Procurement Reference Number:	G/RFQ/NW-008/2027
Subject matter of Procurement:	Supply & Delivery of Steel Pipe Specials, Flexible Couplings, Fasteners and Gaskets for the Ombalantu Raw Water Strainers.

We offer to supply the items listed in the attached List of Goods and Price Schedule as per the defined specifications, *except for the qualified deviations [Bidder may delete this phrase in case of no deviation]* and, in accordance with the terms and conditions stated in your Request for Quotations referenced above.

We confirm that we are eligible to participate in this Quotation exercise and meet the eligibility criteria specified in Section 1: Instruction to Bidders.

We undertake to abide ethical conduct during the procurement process and the execution of any resulting contract.

We have read and understood the content of the Bid Securing Declaration (BSD) attached hereto and subscribe fully to the terms and conditions contained therein. We further understand that this subscription could lead to disqualification on the grounds mentioned in the BD].

The validity period of the Quotation is..... days from the date of the bid submission deadline.

We confirm that the prices quoted in the List of Goods and Price Schedule are fixed and firm and will not be subject to revision or variation, if we are awarded the contract prior to the expiry date of the quotation validity.

The delivery period offered from the date of issue of Purchaser Order/ Letter of Acceptance is as shown in the List of Goods items and Price Schedule.

Quotation Authorised by:

Name of Bidder		Company's Address and seal	
Contact Person			
Name of Person Authorising the Quotation:	Position:	Signature:	
Date		Phone No./Fax	

Initials.....

Appendix to Quotation Letter

BID SECURING DECLARATION
(Section 45 of Act)
(Regulation 37(1)(b) and 37(5))

Date:

Procurement Ref No.:

To:

I/We* understand that in terms of section 45 of the Act a public entity must include in the bidding document the requirement for a declaration as an alternative form of bid security.

I/We* accept that under section 45 of the Act, I/we* may be suspended or disqualified in the event of

- (a) a modification or withdrawal of a bid after the deadline for submission of bids during the period of validity;**
- (b) refusal by a bidder to accept a correction of an error appearing on the face of a bid;**
- (c) failure to sign a procurement contract in accordance with the terms and conditions set forth in the bidding document, should I/We* be successful bidder; or**
- (d) failure to provide security for the performance of the procurement contract if required to do so by the bidding document.**

I/We* understand this bid securing declaration ceases to be valid if I am/We are* not the successful Bidder

Signed:
[insert signature of person whose name and capacity are shown]

Capacity of:
[indicate legal capacity of person(s) signing the Bid Securing Declaration]

Name:
[insert complete name of person signing the Bid Securing Declaration]

Duly authorized to sign the bid for and on behalf of: *[insert complete name of Bidder]*

Dated on _____ day of _____, _____
[insert date of signing]

Corporate Seal (where appropriate)

[Note*: In case of a joint venture, the bid securing declaration must be in the name of all partners to the joint venture that submits the bid.]
****delete if not applicable / appropriate***

Initials.....



Republic of Namibia

Ministry of Labour, Industrial Relations and Employment Creation

Written undertaking in terms of section 138 of the Labour Act, 2015 and section 50(2)(D) of the Public Procurement Act, 2015

1. EMPLOYERS DETAILS

Company Trade Name:.....

Registration Number :.....

VAT Number:

Industry/Sector:

Place of Business:.....

Physical Address:.....

Tel No.:.....

Fax No.:.....

Email Address:.....

Postal Address:.....

Full name of Owner/Accounting Officer:.....

.....

Email Address:.....

Initials.....

2. PROCUREMENT DETAILS

Procurement Reference No.:.....

Procurement Description:

.....

.....

Anticipated Contract Duration:

Location where work will be done, good/services will be delivered:

.....

3. UNDERTAKING

I *[insert full name]*, owner/representative

of*[insert full name of company]*

hereby undertake in writing that my company will at all relevant times comply fully with the relevant provisions of the Labour Act and the Terms and Conditions of Collective Agreements as applicable.

I am fully aware that failure to abide to such shall lead to the action as stipulated in section 138 of the labour Act, 2007, which include but not limited to the cancellation of the contract/licence/grant/permit or concession.

Signature:

Date:

Seal:.....

Please take note:

1. *A labour inspector may conduct unannounced inspections to assess the level of compliance*
2. *This undertaking must be displayed at the workplace where it will be readily accessible and visible by the employees rendering service(s) in relations to the goods and services being procured under this contract.*

Initials.....

	restraining flange on one end and a NB25 PN10 stub							
8	NB300 PN10 Flanged Distance piece	1	Each					
9	NB25 PN10 Blank Flanged with a 25mm Socket	3	Each					
10	NB200 PN10 Klamflex dedicated flange adapter	6	Each					
11	NB200 Pipe supports	6	Each					
12	HDG M12X 45 BOLTS, NUTS & WASHERS	40	Each					
13	HDG M20 X 75 BOLTS	210	Each					
14	HDG M20 HEX NUTS	210	Each					
15	HDG M20 FLAT WASHERS	420	Each					
16	HDG M20 X 1000 TIE ROD	15	Each					
17	NB25 Klinger Gasket	4	Each					
18	NB200 Klinger Gasket	20	Each					
19	NB300 Klinger Gasket	4	Each					
20								
					TOTAL			
NAME:		POSITION:		SIGNATURE			DATE	
NAME OF BIDDER:		ADDRESS:						

If Price quoted is subject to change in rate of exchange at the time of delivery of goods provide details hereunder:

Currency: N\$ Exchange Rate: N/A Key notes: **NA**=NOT APPLICABLE, **NQ**=NO QUOTE

Initials.....

SECTION IV: SPECIFICATIONS AND PERFORMANCE REQUIREMENTS

Pipework

All flanges of fabricated pipe specials shall conform to SANS 1123/1000/3 unless specified otherwise.

Steel pipes shall accordingly either comply with SABS 62 or 719 Grade B/C.

All pipe specials flanges shall be fitted with two-hole-top off the centreline configuration.

All pipework welding shall be done in accordance with SANS 10044 for steel fusion welding. Mating surfaces shall be welded all around their mating periphery.

All pipe sockets shall be rated for PN40.

All pipework shall be marked for easier identification and assembling.

Unless otherwise stated, all manufactured pipe specials shall comply with the following specifications:

Nominal Diameter	Outside Diameter	Wall Thickness (min.)
NB25	33.7	4.5mm
NB80	88.9mm	4.5mm
NB150	168.3mm	4.5mm
200NB	219.1mm	4.5mm
300NB	323.9mm	4.5mm

Flange Adaptors

All steel surfaces shall be blast clean to SABS 064 and the final finishing shall comply with S.I.S. 05 5900 grade Sa 2.5.

Only **Klamflex** flexible pipe couplings shall be acceptable. **The bidder shall submit supporting literature of the couplings offered**

All pipe flexible pipe coupling items shall be coated as according to specifications.

Note: All flange adaptor studs shall be welded on.

Corrosion Protection

All steel surfaces shall be blast clean to SABS 064 and the final finishing shall comply with S.I.S. 05 5900 grade Sa 2.5. before coating or as prescribed by the coating manufacturer.

The wetted surfaces of all pipe specials, flanges and flexible pipe coupling items shall be coated with a minimum of two coats of a Neo Corroguard to a total dry film thickness of 60 -

70 micron strictly according to Manufacturer's specifications. The wetted surface of plain ended pipes shall include 200mm of the external surface of plain end or the external surface of the entire plain end, whichever is less.

All Items shall be **internally coated** (pipe internal surfaces, 150mm of pipe plain end external surfaces and flange faces) shall be coated with a minimum of three (3) coats of blue **Carboline® Carbogaurd® 891**, strictly according to the Carboline®'s specifications. The **external surface** of all items shall be coated with two coats of **Brunswick 4 Green** high gloss paint following Carboline® Carboguard® 891 or primer coating.

All pipework shall be **packaged and/or wrapped** to appropriately protect the coatings from damage during transit. The supplier shall be required to touch-up any areas where the coating has been damaged during transit.

Fasteners

The bolts to be of **grade 4.8** unless stated otherwise. All fasteners where applicable shall be ISO metric according to SABS 135. All bolts, nuts, threaded rods and washers shall be hot dip galvanized as per SABS ISO 1461: 1999. Electroplated bolts, nuts and washers shall not be accepted.

The fasteners shall be packaged in suitable woven bags with appropriate labelling. The bags shall then be crated for transport and delivery.

Gaskets

The gasket OD should be dictated by the flange specifications. The gaskets shall be of non-asbestos compressed fiber or graphite type. The gaskets shall be suitable for potable and raw water at temperatures from 0°C to 60°C. The gaskets shall have a thickness of 3mm. **Full faced gaskets will not be accepted.**

Pipe supports

All pipe supports **external surface** of all items shall be coated with two coats of **Zinga** paint following primer coating.

SECTION V: SPECIFICATIONS AND COMPLIANCE SHEETS

Procurement Reference Number: **Procurement Ref No. G/RFQ/NW-008/2027**

Bidders should complete column C with the specification of the goods offered and **attach annexures with detailed technical literature substantiating compliance**. Offers of equipment failing to comply with one or more of the specifications shall be disqualified. **Failure to complete column C of the Specifications and Compliance Sheet shall result in disqualification.**

Item No	Technical Specification Required	Compliance of Specification Offered	Details of Non-Compliance/ Deviation (if applicable)
<i>A</i>	<i>B</i>	<i>C</i>	<i>D</i>
1 - 10	All flanges shall conform to SANS 1123/1100/3 unless otherwise specified on the drawings		
	Steel pipes shall comply with SABS 62 or 719		
	4.5mm pipe wall thickness (min.)		
	Welding done in accordance with SANS 10044 for steel fusion welding		
	Corrosion protection as specified		
	All flanges fitted with two – holes-top		
	Klamflex dedicated flange adapters suitable for mild steel pipe		
11-15	All fasteners where applicable shall be ISO metric according to SABS 135		
	All fasteners hot dip galvanized as per SABS ISO 1461: 1999		
16-18	Suitable for potable and raw water at temperatures from 0°C to 60°C		
	3mm thickness		
	Ring Klinger gasket (not full faced)		

All bids shall be accompanied with detailed supporting literature for all couplings to enable NamWater to evaluate the conformity to specification and include additional features.

Offers with insufficient details or information will not be considered.

Initials.....

NOTE:

Offers will be disqualified if this information is not included in the tender documents. Only original documentation is acceptable and faxed copies of literature are unacceptable. Information supplied in an electronic format will be accepted if in PDF format.

Specifications and Compliance Sheet Authorised By:

Name:		Signature:	
Position:		Date:	
Authorised for and on behalf of:	Company		

Initials.....

SECTION VI: GENERAL CONDITIONS OF CONTRACT AND CONTRACT AGREEMENT

Any resulting contract shall be placed by means of a Purchase Order/Letter of Acceptance and shall be subject to the General Conditions of Contract (GCC) for the Procurement of Goods (Ref. **G/RFQ-GCC**) available at Namibia Water Corporation Ltd., physical address, 176 Iscor Street, Aigams Building, Windhoek, except where modified by the Special Conditions below

SECTION VI: CONTRACT AGREEMENT

Any resulting contract shall be placed by means of a Purchase Order/Letter of Acceptance and shall be subject to the General Conditions of Contract (GCC) for the Procurement of Goods except where modified by the Special Conditions below.

SECTION VII: SPECIAL CONDITIONS OF CONTRACT

Procurement Reference Number: **G/RFQ/NW-008/2027**

The clause numbers given in the first column correspond to the relevant clause number of the GCC.

Subject and GCC clause reference	Special Conditions
Site GCC 1.1(m)	The Site/final destination for delivery of the Goods is 176 Iscor Street NamWater at the Aigams Building, Northern Industrial Area in Windhoek
Incoterms Edition GCC 4.2(b)	Incoterms shall be governed by the rules prescribed in Incoterms 2010.
Notices GCC 8.1	Any notice shall be sent to the following addresses: For NamWater Ltd the address and the contact name shall be: Procurement Management Unit (Tel: +264 61 71 2015), E-mail: bids@namwater.com.na Private Bag 13389 Windhoek, Namibia For the Supplier, the address and contact name shall be: _____
Delivery and Documents GCC 13.1	The Goods are to be delivered within 4 Weeks from the date of Purchase Order or Letter of Acceptance. The documents to be furnished by the Supplier are: (a) signed delivery note; (b) invoice

Initials.....

Subject and GCC clause reference	Special Conditions
Terms of Payment GCC 16.1	The structure of payments shall be: full payment following delivery of the Supplies and submission of an invoice and the documents listed in clause 13.1
Terms of Payment GCC 16.3	Payments shall be made not later than thirty days after date of statement and upon submission of an invoice and its certification by the Purchaser. Payment will only be made if all the delivered items are to specifications
Terms of Payment GCC 16.4	The currency of payment shall be the currency of order specified in the List of Goods, Price Schedule and Product details in the Statement of Requirements.
Transportation GCC 25	The Goods shall be delivered: Delivery Duty Paid (DDP)
Inspection and Tests GCC 26.	NamWater will inspect all items upon delivery to ascertain if goods conform to specifications. Payment will only be made if all the delivered items are to specifications.
Liquidated Damages GCC 27	Liquidated damages for the whole contract are 0.5% per day. The maximum amount of liquidated damages for the whole contract is 10% of the final contract price.
Warranty GCC 28.3	The period of validity of the warranty shall be: N/A
Repair and Replacement GCC 28.5	The period for repair or replacement shall be : N/A

Initials.....

SCHEDULE 3: QUOTATION CHECKLIST SCHEDULE**Procurement Reference No.: G/RFQ/NW-008/2027**

Description	Attached	Not Attached
List of Goods and Price Schedule		
Specification and Compliance Sheet		
Evidences for conformity of Goods		
valid copy of company registration / founding statement. (certified by a Commissioner of Oath appointed in terms of the Justices of the Peace and Commissioners of Oaths Act.1963 (Act No. 16 of 1963))		
Original or certified copy of valid good Standing TAX Certificate; (certified by a Commissioner of Oath appointed in terms of the Justices of the Peace and Commissioners of Oaths Act.1963 (Act No. 16 of 1963))		
Valid good Standing Social Security Certificate;		
A certified copy of a valid Affirmative Action Compliance Certificate, or proof from Employment Equity Commissioner that bidder is not a relevant employer, or exemption issued in terms of Section 42 of the Affirmative Action Act, 1998; (certified by a Commissioner of Oath appointed in terms of the Justices of the Peace and Commissioners of Oaths Act.1963 (Act No. 16 of 1963))		
Submit signed Bid-securing Declaration.		
An undertaking on the part of the Bidder that the salaries and wages payable to its personnel in respect of this proposal are compliant to the relevant laws, Remuneration Order, and Award, where applicable and that it will abide to sub-clause 4.6 of the General conditions of Contract if it is awarded the contract or part thereof; and		
Submit supporting literature to substantiate compliance. These documents must be from the manufacturer or an authorized manufacturer's representative of the offered goods. Representatives must provide an authorization letter from the manufacturer confirming their status..		

Disclaimer: The list defined above is meant to assist the Bidder in submitting the relevant documents and shall not be a ground for the bidder to justify its non-submission of major documents for its quotation to be responsive. The onus remains on the Bidder to ascertain that it has submitted all the documents that have been requested and are needed for its submission to be complete and responsive.

Initials.....

NOTES :

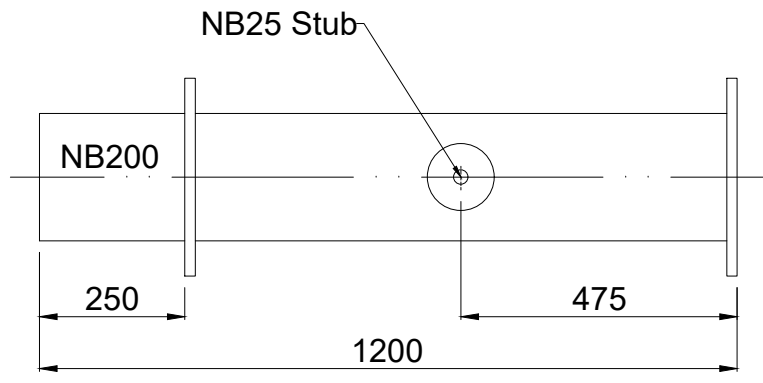

ITEM: 1

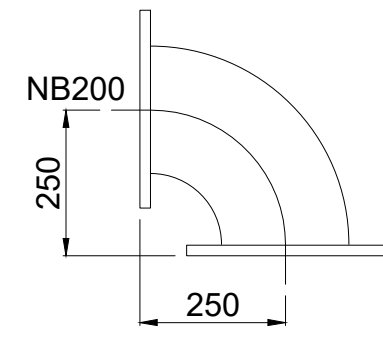

ITEM: 2

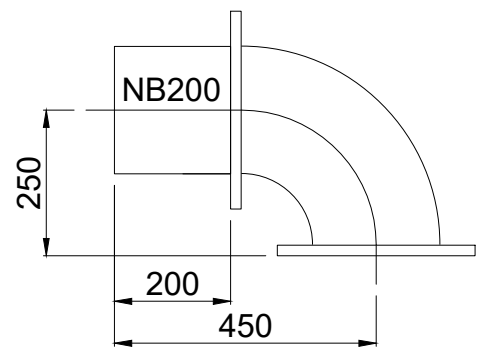

ITEM: 3

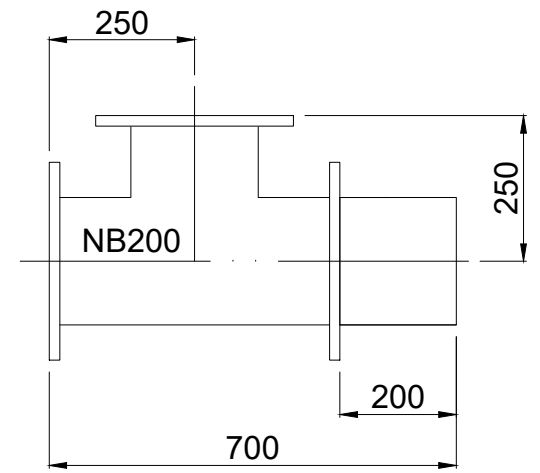

ITEM: 4

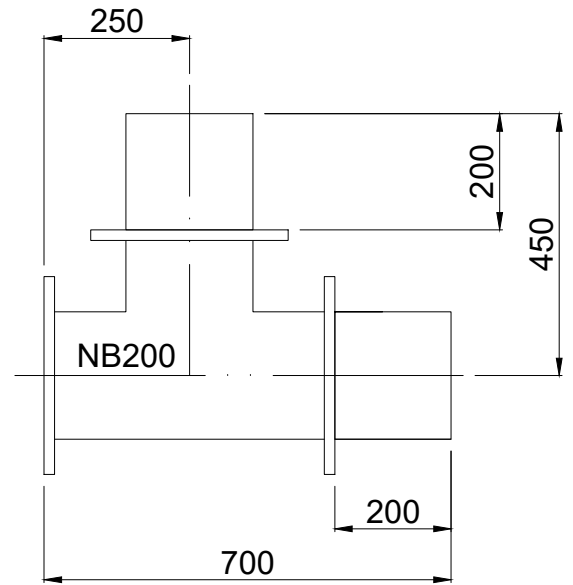

ITEM: 5

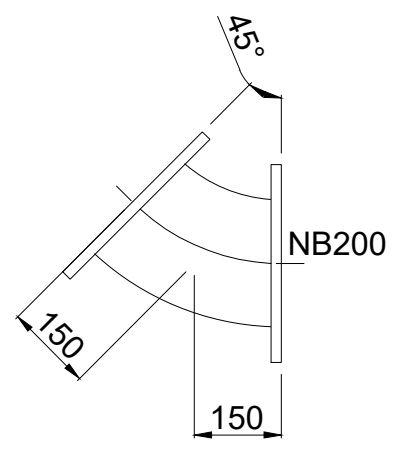

ITEM: 6

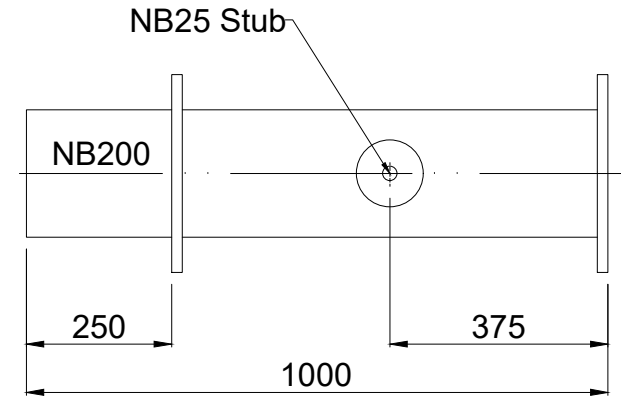

ITEM: 7

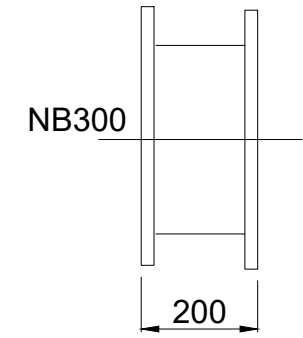

ITEM: 8

AMENDMENTS	DATE	BY



SCHEME
OMBALANTU RAW WATER

DRAWING
DETAILED PIPEWORK

	DRAWN ET KASITA	TRACED AUTOCAD
DESIGNED CIVIL	DESIGNED ELEC.	DESIGNED MECH. ET KASITA
CHECKED CIVIL	CHECKED ELEC.	CHECKED MECH.
APPROVED CIVIL	APPROVED ELEC.	APPROVED MECH.

GENERAL MANAGER ENGINEERING AND SCIENTIFIC SERVICES
 FEBRUARY 2026 SCALE: 1:13 SHEET NO. 1 OF 2
 REGISTRATION NO. A3

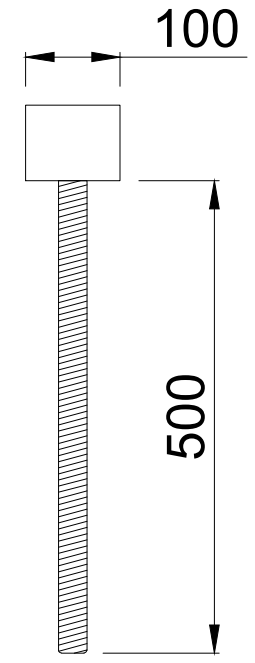
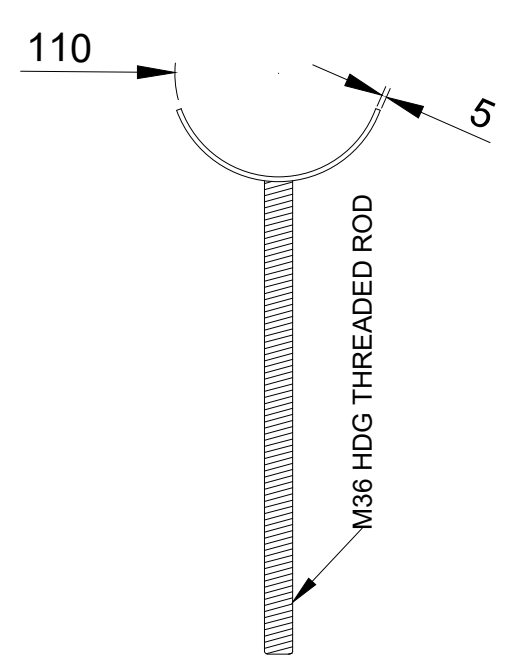
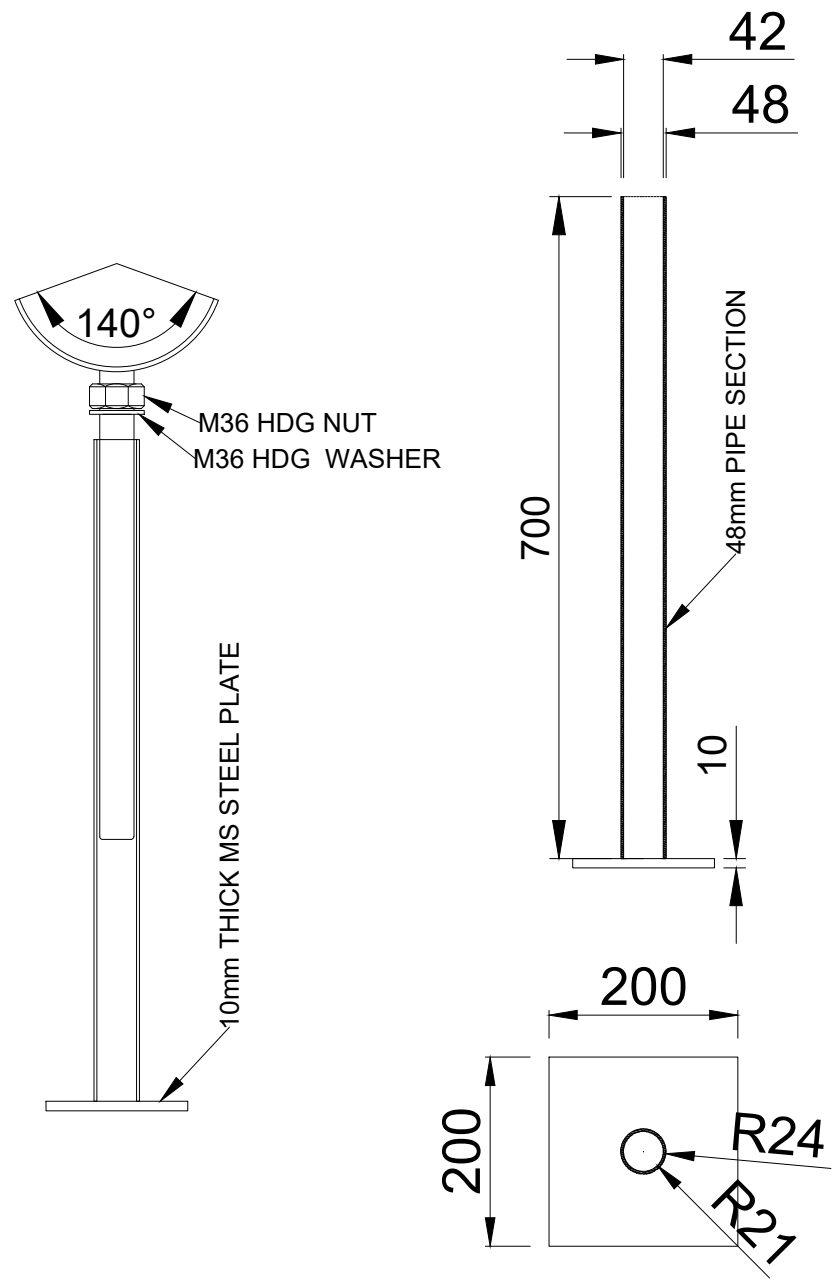

ITEM 11

NOTES :

AMENDMENTS	DATE	BY



SCHEME
OMBALANTU RAW WATER

DRAWING
DETAILED PIPEWORK

	DRAWN ET KASITA	TRACED AUTOCAD
DESIGNED CIVIL	DESIGNED ELEC.	DESIGNED MECH. ET KASITA
CHECKED CIVIL	CHECKED ELEC.	CHECKED MECH.
APPROVED CIVIL	APPROVED ELEC.	APPROVED MECH.

GENERAL MANAGER ENGINEERING AND SCIENTIFIC SERVICES
 FEBRUARY 2026 SCALE 1:8 SHEET NO. 2 OF 2
 REGISTRATION NO. A3